

7.5 - 8.5 METRIC TON



JOHN DEERE

D

EXCAVATORS

75D 85D





Regular or swing boom. Steel or rubber tracks.

It's nice to have choices. Whether you're landscaping or doing light residential excavating, site development, or underground work, the new conventional-boom 75D and swing-boom 85D will have an immediate impact on your bottom line. Neither too big nor too small, these right-size machines deliver all the power, smoothness, control, and ease of operation you've come to expect from larger John Deere excavators in an easy-to-maneuver package. Their compact size and reduced tail-swing design allow them to rotate freely within a small radius. So they're

more productive in confined spaces and around obstacles. With increased swing torque and drawbar pull, they produce like a big-time machine. And with a spacious, comfortable cab featuring an advanced LCD monitor, they operate like one, too. Rubber tracks are now optional on both models. Other enhancements including a high-efficiency cooling system; rugged, turbo-charged, fuel-efficient Interim Tier 4 diesel; and improved serviceability ensure the uptime and long-lasting durability you've come to expect from Deere.



Reduced tail swing allows operators to get closer to objects on congested jobsites, for extra versatility and maneuverability in close quarters.

The 75D features a standard boom while the 85D features a versatile swing boom for digging parallel to walls and foundations. Rubber tracks are optional on both models.

Spacious operating station with generous legroom and more glass delivers the comfort and visibility you'd expect from a large excavator, within the footprint of a small machine.

Quiet-running Interim Tier 4 emission-certified diesels deliver more torque with impressive fuel efficiency. Turbocharging lets them work at higher altitudes without sacrificing performance.

Extended engine and hydraulic oil-service intervals help maximize uptime and reduce daily operating costs.

Powerwise III™ engine/hydraulic management system maximizes power output, saves fuel, and delivers smooth multifunction hydraulic operation.

Specifications	75D	85D
Net Power	54 hp (40.5 kW)	54 hp (40.5 kW)
Operating Weight	17,743 lb. (8048 kg)	18,821 lb. (8537 kg)
Lift Capacity	4,248 lb. (1927 kg)	4,248 lb. (1927 kg)
Digging Depth	13 ft. 6 in. (4.11 m)	13 ft. 0 in. (3.97 m)
Arm Breakout Force	8,554 lb. (38.1 kN)	8,554 lb. (38.1 kN)

For work that requires extra finesse, best-in-class metering and superb multifunction operation deliver the precise control you need and that John Deere excavators are known for.

Optional, durable rubber tracks let you cross driveways and sidewalks without damage — perfect for landscaping jobs on existing properties.

The 75D and 85D are sized to transport easily between jobsites.

Generous hydraulic flow combined with increased swing torque help you load more trucks and open more trench.

With their narrow width, reduced tail swing, and rubber track option, these excavators tackle tasks that used to be handwork.

Choose from a variety of track widths, arm lengths, buckets, and other options to maximize your efforts.

Hydraulic recirculation system delivers more efficient flow to the boom and arm, speeding multifunction operation and cycle times.

Additional hydraulic capability a necessity? Optional high-pressure, high-flow auxiliary hydraulic packages meet the need.



1

1. Need even more digging depth or reach? Choose the long-arm option.

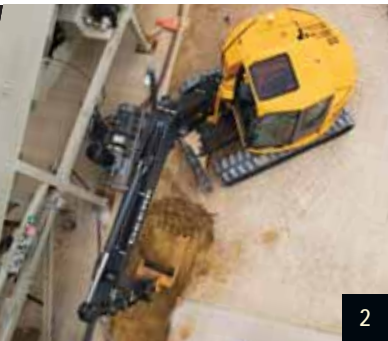

2

2. Why allow obstacles to dictate how you work? Three-hundred-sixty-degree rotation and independent-swing boom (on the 85D) let you get tight and dig parallel to walls.

3. Standard integral blade helps to conveniently accomplish backfill tasks. New shape moves more dirt and improves visibility.



3



4

4. High sideboards are no problem for these excavators. Plenty of lift height and reach make truck loading easy.





These hard workers won't work their tails off.

Don't get us wrong. With outstanding digging force, swing torque, drawbar pull, and lift capability, the 75D and 85D are highly productive, hard-working machines. But with their tight tail swing, operators can concentrate on the work in front of them without worrying about damaging the machine or surroundings behind them — productivity in confined

areas soars. Control is smooth and effortless, with the Powerwise III management system delivering pinpoint metering. Highly maneuverable and easy to transport, they're perfect for landscapers and small contractors. Who says you have to work your tail off to be more productive?

The image shows the operator's cab of a John Deere D-Series Excavator. The interior is primarily grey and white, with a prominent yellow panel at the top. This panel features several safety warnings, including a red 'DANGER' sign with a diagram of a person being struck, a yellow 'CAUTION' sign, and a black 'WARNING' sign. The operator's seat is a blue, textured multi-position seat. In the center, there is a large, white, ergonomic joystick for the boom and bucket. To the left, there is a control panel with a small LCD monitor and various buttons. The overall environment is clean, organized, and designed for operator comfort and safety.

A comfortable environment for getting more done.

Climb aboard a D-Series Excavator, and you'll discover the many reasons why operators are more productive in a John Deere. A spacious, well-appointed cab with substantially more legroom and virtually unrestricted visibility. Ergonomically arranged controls and an intuitive, multifunction LCD monitor. And all

the creature comforts and conveniences that take the sting out of a long shift. Like automatic climate control, AM/FM radio, and deluxe-suspension multi-position seat. At the end of the day, your operators will be comfortably productive. And you'll feel comfortable about your bottom line.



Noise levels — and operator fatigue — have been significantly reduced. Noise-reducing muffler and isochronous high-idle speed help quiet things down.

Ergonomic short-throw pilot levers provide smooth, predictable fingertip control with less effort.

Go from backhoe- to excavator-style controls with just a twist of the optional control-pattern selector valve.

Convenient 12-volt port powers cell phones and other electronic devices.

Redesigned cab isn't just roomier, it's also noticeably more comfortable. Silicone-filled cab mounts effectively isolate operators from noise and vibration.

The specially designed cab on the 85D accommodates the swing boom without sacrificing comfort and visibility.

Intuitive, multi-language monitor with four-color LCD screen provides a wealth of info and control. Displays operating, diagnostic, and maintenance data with easy-on-the-eyes clarity.

1. A large expanse of glass on the right-hand side, narrow front cab posts, large tinted overhead hatch (window only on 85D), and numerous mirrors provide clear all-around visibility.

2. Both the 75D and 85D cabs include a cup holder, and the 75D also has a storage box for a cell phone, keys, and other small items.

3. Automatic, high-velocity bi-level climate-control system with automotive-style adjustable louvers helps keep the glass clear and the cab comfortable.

4. Deluxe-suspension multi-position seat features multiple adjustments to fit a variety of operators. It slides with, or independent of, the control console so it won't cramp the operator's style (75D shown).



Oil-impregnated bushings enhance durability and extend grease intervals to 500 hours (100 hours for the bucket joint). Reinforced resin plates increase boom-lube intervals to 500 hours.

Tungsten-carbide coating creates an extremely wear-resistant surface to protect the all-important bucket-to-arm joint.

Optional rubber tracks feature a unique steel core that resists cracking.

With large idlers, rollers, and strutted links, the sealed and lubricated undercarriage delivers long and reliable performance.

Wet-disk swing brake delivers long-term maintenance-free performance.

Heavy-duty shields deflect material and impacts, protecting the propel motors and boom and blade cylinders.

O-ring face-seal couplers virtually eliminate leaks.

Heavy-duty welded x-frame provides a solid, stable platform that resists material buildup.

A linear clutch continuously adjusts to fan speed to reduce noise and fuel consumption. You'll be amazed how quietly and efficiently these machines run.



1. Wear-resistant hoses are protected and secured to prevent excessive tension.
2. Welded bulkheads within the boom resist torsional stress.
3. Rigid, reinforced D-channel side frames resist impact, providing maximum cab and component protection.
4. Box-section track frames, thick-plate single-sheet mainframe, and large swing bearing deliver rock-solid durability.



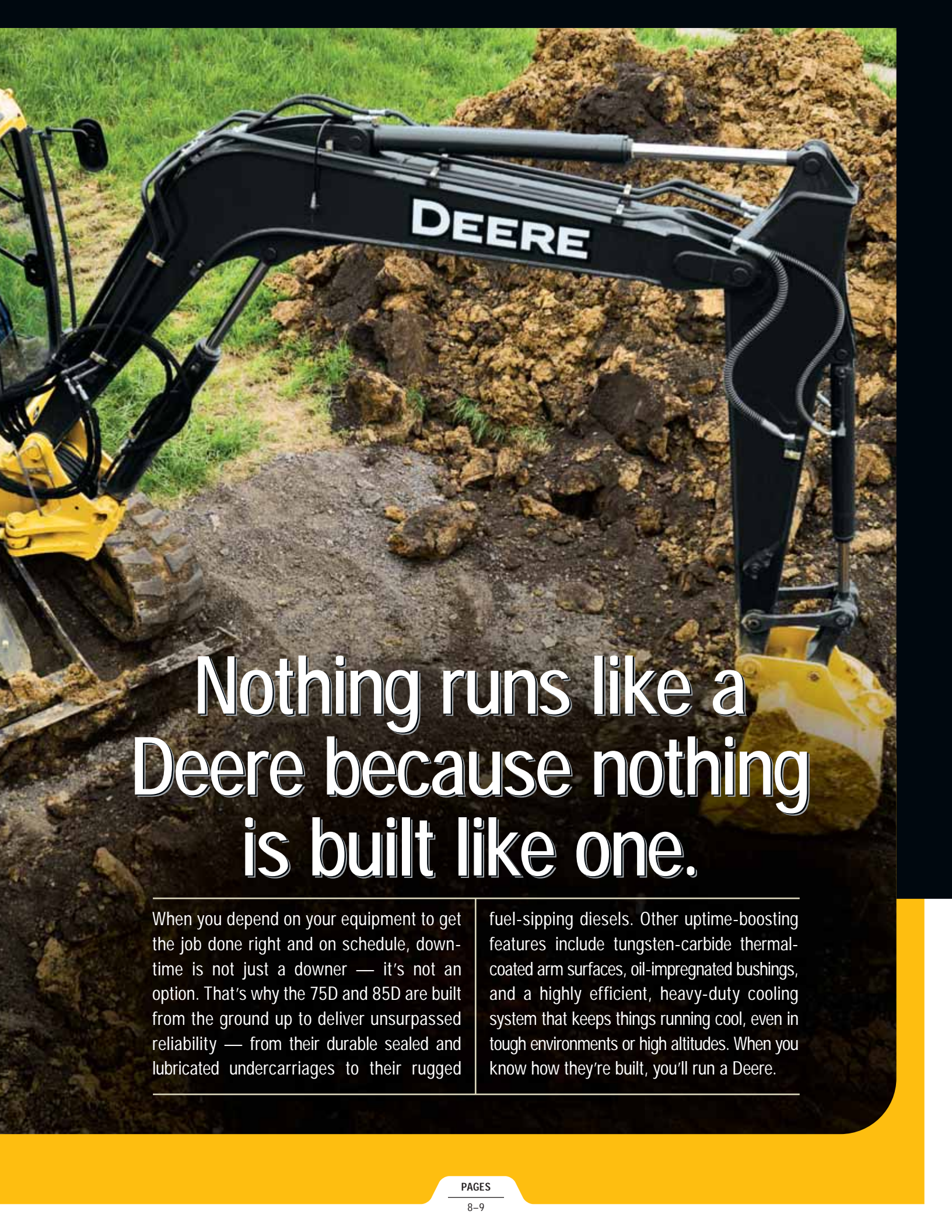

Nothing runs like a Deere because nothing is built like one.

When you depend on your equipment to get the job done right and on schedule, downtime is not just a downer — it's not an option. That's why the 75D and 85D are built from the ground up to deliver unsurpassed reliability — from their durable sealed and lubricated undercarriages to their rugged

fuel-sipping diesels. Other uptime-boosting features include tungsten-carbide thermal-coated arm surfaces, oil-impregnated bushings, and a highly efficient, heavy-duty cooling system that keeps things running cool, even in tough environments or high altitudes. When you know how they're built, you'll run a Deere.

Large fuel tanks and 500- and 5,000-hour engine and hydraulic oil-service intervals help increase uptime and lower daily operating costs.

Remote fillers make fluid servicing fast and easy.

Large, easy-to-open doors provide quick access to service items. Lube banks, filters, and checkpoints are grouped for added convenience.

Machine Information Center (MIC) captures and stores vital machine performance and utilization data to help improve uptime, productivity, and profit.

Using the easy-to-navigate LCD color monitor, you can easily keep tabs on up to 14 maintenance intervals and 32 machine operating parameters.



We're open-minded when it comes to simplifying service.

We're always open to ideas that make our excavators simpler to service and lower cost to maintain. Like large, easy-to-open service doors that provide ample access to conveniently grouped service points. And extended service intervals and remote-mounted vertical oil and

fuel filters that speed periodic maintenance. So you can spend less time on machine upkeep, and more time doing the real work of increasing your bottom line. Industry-leading parts and service are easy to access, too, at more than 400 John Deere locations.

1. Vertical spin-on fuel/water filters are positioned in the right rear compartment, simplifying service.

2. Conveniently located sight gauges let you check coolant and hydraulic fluid levels at a glance.

3. The left-hand, rear compartment provides access to the battery, washer fluid, air filter, and side-by-side cooling cores.

4. The 75D's fresh-air cab filter is quickly serviced at ground level where it's more likely to get done.



Nobody backs you better than the 400-plus John Deere dealers throughout North America.

Specifications

Engine 75D

Manufacturer and Model	Isuzu 4LE2X
Non-Road Emission Standards	certified to EPA interim Tier 4 emissions
Net Power (ISO9249)	54 hp (40.5 kW) @ 2,000 rpm
Cylinders	4
Displacement	133 cu. in. (2.2 L)
Off-Level Capacity	70% (35 deg.)
Aspiration	turbocharged with intercooler

Cooling

Variable-speed fan directly driven by the engine through a linear clutch; nonreversible

Powertrain

Two-speed propel with automatic shift	
Travel Speed (maximum)	
Low	1.9 mph (3.1 km/h)
High	3.1 mph (5.0 km/h)

Hydraulics

Open center, load sensing	
Main Pumps	3 variable-displacement axial piston
Maximum Rated Flow	2 x 20.9 gpm + 16.3 gpm (2 x 79.2 lpm + 61.6 lpm)
Pilot Pump	one gear
Maximum Rated Flow	5.3 gpm (20 L/m)
System Relief Pressure	566 psi (3900 kPa)
System Operating Pressure	
Implement Circuits	3,771 psi (26 000 kPa)
Travel Circuits	4,554 psi (31 400 kPa)
Swing Circuits	3,626 psi (25 000 kPa)
Controls	pilot levers, short stroke, low effort; hydraulic pilot controls with shutoff lever

Cylinders

Heat-treated, chrome-plated, polished cylinder rods, hardened steel (replaceable bushings) pivot pins			
	<i>Bore</i>	<i>Rod Diameter</i>	<i>Stroke</i>
Boom (1)	4.5 in. (115 mm)	2.6 in. (65 mm)	34.8 in. (885 mm)
Arm (1)	3.7 in. (95 mm)	2.4 in. (60 mm)	35.4 in. (900 mm)
Bucket (1)	3.3 in. (85 mm)	2.2 in. (55 mm)	28.7 in. (730 mm)

Electrical

Batteries	2 x 12 volt
Reserve Capacity	100 min.
Alternator Rating	50 amp
Work Lights	halogen (2), one mounted on boom and one on frame

Undercarriage

Carrier Rollers (per side)	1
Track Rollers (per side)	5
Shoes, Triple Semi-Grouser (per side)	40
Drawbar Pull	14,661 lb. (6650 kg)
Track	
Adjustment	hydraulic
Chain	sealed and lubricated

Swing Mechanism

75D

Swing Speed	10.5 rpm
Swing Torque	12,244 lb.-ft. (16 600 Nm)

Ground Pressure

24-in. (600 mm) Triple Semi-Grouser Shoes	3.7 psi (26 kPa)
18-in. (450 mm) Rubber Crawler Pads	4.9 psi (34 kPa)
18-in. (450 mm) Rubber Crawler Belt	4.9 psi (34 kPa)

Serviceability

Refill Capacities

Fuel Tank	35.7 gal. (135 L)
Cooling System	2.7 gal. (10.3 L)
Engine Oil with Filter	3.2 gal. (12.1 L)
Hydraulic Tank	15 gal. (56 L)
Hydraulic System	26 gal. (100 L)
Propel Gearbox (each)	1.3 qt. (1.2 L)

Operating Weights

With Full Fuel Tank; 175-lb. (79 kg) Operator;	
0.53-cu.-yd. (0.41 m ³), 30-in. (762 mm),	
735-lb. (333 kg) Bucket; 5-ft. 4-in. (1.62 m)	
Arm; 3,049-lb. (1383 kg) Counterweight;	
and 8-ft. 1-in. (2470 mm) Blade	
24-in. (600 mm) Triple Semi-Grouser Shoes	17,743 lb. (8048 kg)
18-in. (450 mm) Rubber Crawler Pads	17,461 lb. (7920 kg)
18-in. (450 mm) Rubber Crawler Belt	17,412 lb. (7898 kg)

Optional Components

Undercarriage	
24-in. (600 mm) Triple Semi-Grouser	
Shoes	3,366 lb. (1527 kg)
18-in. (450 mm) Rubber Crawler Pads	3,036 lb. (1377 kg)
One-Piece Boom (with arm cylinder)	1,025 lb. (465 kg)
Arm with Bucket Cylinder and Linkage	
5 ft. 4 in. (1.62 m)	514 lb. (233 kg)
6 ft. 11 in. (2.12 m)	595 lb. (270 kg)
Boom Lift Cylinder	196 lb. (89 kg)
Counterweight (standard)	3,049 lb. (1383 kg)

Operating Dimensions

	Arm Length 5 ft. 4 in. (1.62 m)	Arm Length 6 ft. 11 in. (2.12 m)
Arm Force	8,554 lb. (38.1 kN)	7,209 lb. (32.1 kN)
Bucket Digging Force	12,368 lb. (55.0 kN)	12,368 lb. (55.0 kN)
Lifting Capacity Over Front at Ground Level		
20-ft. (6.1 m) Reach	4,248 lb. (1927 kg)	4,151 lb. (1883 kg)
A Maximum Reach	21 ft. 1 in. (6.43 m)	22 ft. 8 in. (6.92 m)
A' Maximum Reach at Ground Level	20 ft. 6 in. (6.26 m)	22 ft. 2 in. (6.76 m)
B Maximum Digging Depth	13 ft. 6 in. (4.11 m)	15 ft. 1 in. (4.61 m)
B' Maximum Digging Depth at 8-ft. (2.44 m)		
Flat Bottom	12 ft. 4 in. (3.76 m)	14 ft. 2 in. (4.33 m)
C Maximum Cutting Height	23 ft. 8 in. (7.21 m)	25 ft. 0 in. (7.61 m)
D Maximum Dumping Height	16 ft. 10 in. (5.12 m)	18 ft. 1 in. (5.51 m)
E Minimum Swing Radius	5 ft. 11 in. (1.80 m)	7 ft. 1 in. (2.16 m)
F Maximum Vertical Wall	12 ft. 0 in. (3.67 m)	13 ft. 10 in. (4.22 m)
G Tail Swing Radius	4 ft. 3 in. (1.29 m)	4 ft. 3 in. (1.29 m)

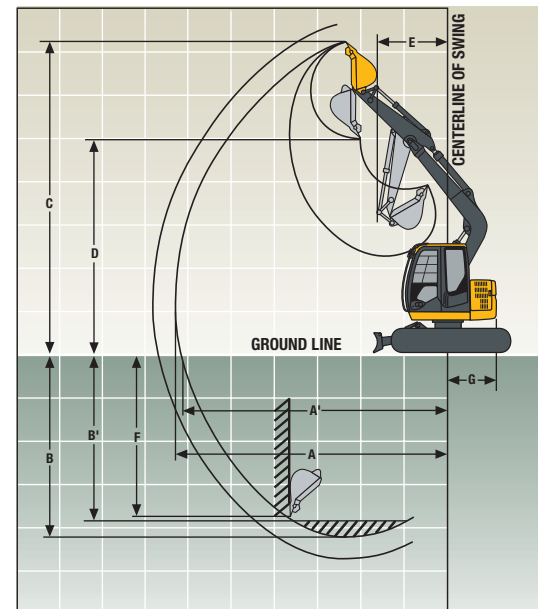

Machine Dimensions

75D

	Arm Length 5 ft. 4 in. (1.62 m)	Arm Length 6 ft. 11 in. (2.12 m)
A Overall Length	20 ft. 8 in. (6.30 m)	20 ft. 11 in. (6.37 m)
B Overall Height	8 ft. 6 in. (2.60 m)	9 ft. 3 in. (2.83 m)
C Overall Width with Blade: 24-in. (600 mm) Triple Semi-Grouser Shoes	8 ft. 1 in. (2.47 m)	
Track Height	26 in. (0.65 m)	
18-in. (450 mm) Rubber Crawler Pads	7 ft. 7 in. (2.32 m)	
18-in. (450 mm) Rubber Crawler Belt	7 ft. 7 in. (2.32 m)	
D Rear-End Length/Swing Radius	4 ft. 3 in. (1.29 m)	
E Distance Between Idler/Sprocket Centerline	7 ft. 6 in. (2.29 m)	
F Undercarriage Length	9 ft. 7 in. (2.92 m)	
G Counterweight Clearance	30 in. (0.76 m)	
H Cab Height	8 ft. 10 in. (2.69 m)	
I Ground Clearance	14 in. (360 mm)	
J Upperstructure Width	7 ft. 5 in. (2.25 m)	
K Gauge Width	6 ft. 2 in. (1.87 m)	
L Blade Lift Height	15 in. (380 mm)	
M Blade Cut Below Grade	11 in. (280 mm)	
N Blade Lift Angle	27 deg.	
Blade Height	18 in. (460 mm)	

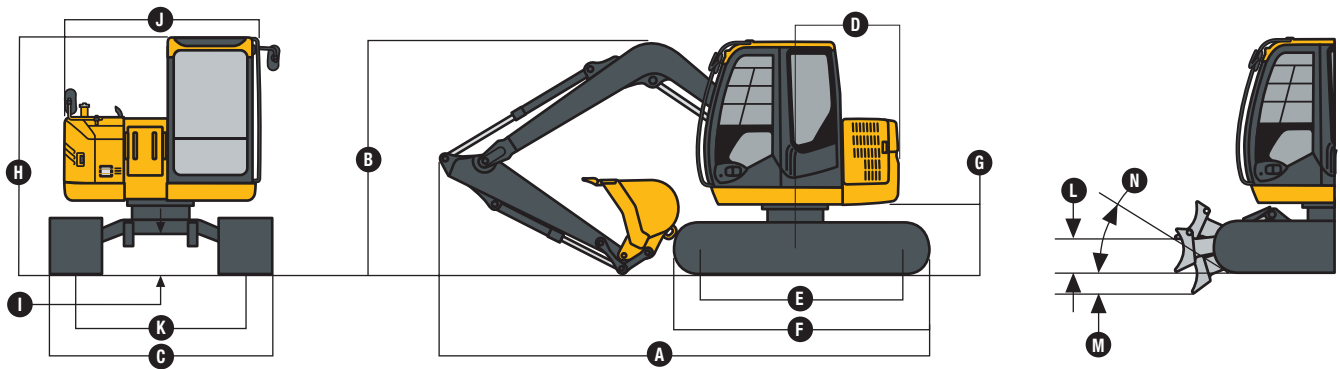

Lift Capacities

Boldface italic type indicates hydraulic-limited capacities; lightface type indicates stability-limited capacities, in lb. (kg). Ratings at bucket lift hook; machine equipped with 12-ft. 8-in. (3.72 m) boom, 0.37-cu.-yd. (0.28 m³) bucket; and situated on firm, uniform supporting surface. Total load includes weight of cables, hook, etc. Figures do not exceed 87 percent of hydraulic capacities or 75 percent of weight needed to tip machine. All lift capacities are based on SAE J1097.

Load Point Height	10 ft. (3.05 m)		15 ft. (4.57 m)		20 ft. (6.10 m)	
	Over Front	Over Side	Over Front	Over Side	Over Front	Over Side
<i>With 5-ft. 4-in. (1.62 m) arm, either 18-in. (450 mm) rubber crawler pads or 18-in. (450 mm) rubber crawler belt, and 7-ft. 7-in. (2.32 m) blade on ground</i>						
10 ft. (3.05 m)	3,821 (1733)	3,821 (1733)	3,265 (1481)	3,163 (1435)		
5 ft. (1.52 m)	6,566 (2978)	5,570 (2527)	4,056 (1840)	2,987 (1355)		
Ground Line	7,676 (3482)	5,286 (2398)	4,709 (2136)	2,842 (1289)		
-5 ft. (-1.52 m)	7,249 (3288)	5,285 (2397)	4,657 (2112)	2,807 (1273)		
-10 ft. (-3.05 m)	5,260 (2386)	5,260 (2386)				
<i>With 6-ft. 11-in. (2.12 m) arm, either 18-in. (450 mm) rubber crawler pads or 18-in. (450 mm) rubber crawler belt, and 7-ft. 7-in. (2.32 m) blade on ground</i>						
15 ft. (4.57 m)			2,464 (1118)	2,464 (1118)		
10 ft. (3.05 m)	2,871 (1302)	2,871 (1302)	2,775 (1259)	2,775 (1259)		
5 ft. (1.52 m)	5,593 (2537)	5,593 (2537)	3,656 (1658)	3,006 (1363)	3,073 (1394)	1,838 (834)
Ground Line	7,400 (3357)	5,285 (2397)	4,479 (2032)	2,824 (1281)	2,816 (1277)	1,776 (806)
-5 ft. (-1.52 m)	7,486 (3396)	5,202 (2360)	4,721 (2141)	2,748 (1246)		
-10 ft. (-3.05 m)	6,187 (2806)	5,312 (2409)				

Lift Capacities (continued)

75D

Boldface italic type indicates hydraulic-limited capacities; lightface type indicates stability-limited capacities, in lb. (kg). Ratings at bucket lift hook; machine equipped with 12-ft. 8-in. (3.72 m) boom, 0.37-cu.-yd. (0.28 m³) bucket; and situated on firm, uniform supporting surface. Total load includes weight of cables, hook, etc. Figures do not exceed 87 percent of hydraulic capacities or 75 percent of weight needed to tip machine. All lift capacities are based on SAE J1097.

Load Point Height	10 ft. (3.05 m)		15 ft. (4.57 m)		20 ft. (6.10 m)	
	Over Front	Over Side	Over Front	Over Side	Over Front	Over Side
<i>With 5-ft. 4-in. (1.62 m) arm, 24-in. (600 mm) triple semi-grouser shoes, and 8-ft. 1-in. (2.47 m) blade on ground</i>						
10 ft. (3.05 m)	3,821 (1733)	3,821 (1733)	3,265 (1481)	3,426 (1554)		
5 ft. (1.52 m)	6,566 (2978)	5,714 (2592)	4,056 (1840)	3,070 (1393)		
Ground Line	7,676 (3482)	5,430 (2463)	4,709 (2136)	2,924 (1326)		
-5 ft. (-1.52 m)	7,249 (3288)	5,429 (2463)	4,657 (2112)	2,890 (1311)		
-10 ft. (-3.05 m)	5,260 (2386)	5,260 (2386)				
<i>With 6-ft. 11-in. (2.12 m) arm, 24-in. (600 mm) triple semi-grouser shoes, and 8-ft. 1-in. (2.47 m) blade on ground</i>						
15 ft. (4.57 m)			2,464 (1118)	2,464 (1118)		
10 ft. (3.05 m)	2,871 (1302)	2,871 (1302)	2,775 (1259)	2,775 (1259)		
5 ft. (1.52 m)	5,593 (2537)	5,593 (2537)	3,656 (1658)	3,089 (1401)	3,073 (1394)	1,896 (860)
Ground Line	7,400 (3357)	5,429 (2463)	4,479 (2032)	2,907 (1319)	2,816 (1277)	1,834 (832)
-5 ft. (-1.52 m)	7,486 (3396)	5,346 (2425)	4,721 (2141)	2,831 (1284)		
-10 ft. (-3.05 m)	6,187 (2806)	5,456 (2475)				

Buckets

A full line of buckets is offered to meet a wide variety of applications. Tooth selection includes either the John Deere Fanggs®, Standard, Tiger, Twin Tiger, Abrasion panel, or Flare tooth, or the ESCO (Vertalok) Standard, Tiger, Twin Tiger, or Flare tooth. Replaceable cutting edges are available through John Deere parts. Optional side cutters add 6 inches (150 mm) to bucket widths.

Type Bucket	Bucket Width		Bucket Capacity*		Weight		Bucket Dig Force		Arm Dig Force 5 ft. 4 in. (1.62 m)		Arm Dig Force 6 ft. 11 in. (2.12 m)		Bucket Tip Radius		No. Teeth
	in.	mm	cu. yd.	m ³	lb.	kg	lb.	kN	lb.	kN	lb.	kN	in.	mm	
Heavy-Duty	24	610	0.40	0.31	633	287	12,061	54.0	8,491	38.0	7,162	32.0	42.80	1087	5
	30	762	0.53	0.41	735	333	12,061	54.0	8,491	38.0	7,162	32.0	42.80	1087	6
	36	914	0.66	0.50	837	380	12,061	54.0	8,491	38.0	7,162	32.0	42.80	1087	7
Ditching	48	1219	0.64	0.49	727	330	14,344	64.0	8,911	40.0	7,473	33.0	35.69	907	0

*All capacities are SAE heaped ratings.

Bucket Selection Guide*

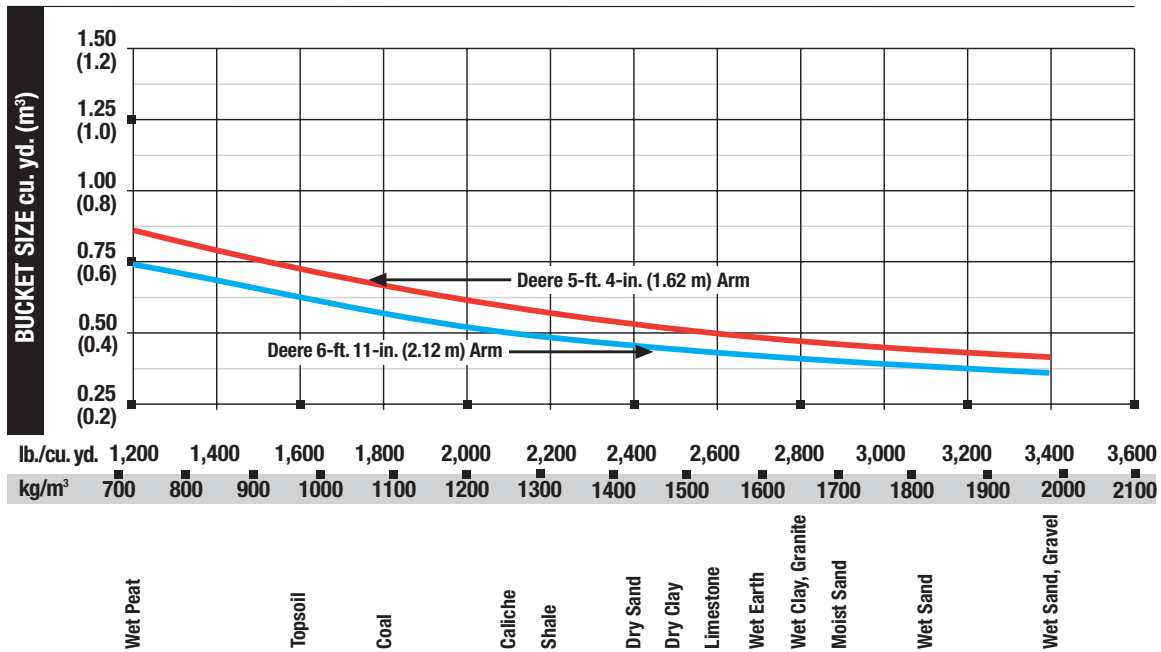

*Contact your John Deere dealer for optimum bucket and attachment selections. These recommendations are for general conditions and average use. Does not include optional equipment such as thumbs or couplers. Larger buckets may be possible when using light materials, for flat and level operations, less compacted materials, and volume loading applications such as mass excavation applications in ideal conditions. Smaller buckets are recommended for adverse conditions such as off-level applications, rocks, and uneven surfaces. Bucket capacity indicated is SAE heaped.

Specifications

Engine 85D

Manufacturer and Model	Isuzu 4LE2X
Non-Road Emission Standards	certified to EPA interim Tier 4 emissions
Net Power (ISO9249)	54 hp (40.5 kW) @ 2,000 rpm
Cylinders	4
Displacement	133 cu. in. (2.2 L)
Off-Level Capacity	70% (35 deg.)
Aspiration	turbocharged with intercooler

Cooling

Variable-speed fan, directly driven by the engine through a linear clutch; nonreversible

Powertrain

Two-speed propel with automatic shift	
Travel Speed (maximum)	
Low	1.9 mph (3.1 km/h)
High	3.1 mph (5.0 km/h)

Hydraulics

Open center, load sensing	
Main Pumps	3 variable-displacement axial piston
Maximum Rated Flow	2 x 20.9 gpm + 16.3 gpm (2 x 79.2 lpm + 61.6 lpm)
Pilot Pump	one gear
Maximum Rated Flow	5.3 gpm (20 L/m)
System Relief Pressure	566 psi (3900 kPa)
System Operating Pressure	
Implement Circuits	3,771 psi (26 000 kPa)
Travel Circuits	4,554 psi (31 400 kPa)
Swing Circuits	3,626 psi (25 000 kPa)
Controls	pilot levers, short stroke, low effort; hydraulic pilot controls with shutoff lever

Cylinders

Heat-treated, chrome-plated, polished cylinder rods, hardened steel (replaceable bushings) pivot pins			
	<i>Bore</i>	<i>Rod Diameter</i>	<i>Stroke</i>
Boom (1)	4.5 in. (115 mm)	2.6 in. (65 mm)	34.8 in. (885 mm)
Arm (1)	3.7 in. (95 mm)	2.4 in. (60 mm)	35.4 in. (900 mm)
Bucket (1)	3.3 in. (85 mm)	2.2 in. (55 mm)	28.7 in. (730 mm)

Electrical

Batteries	2 x 12 volt
Reserve Capacity	100 min.
Alternator Rating	50 amp
Work Lights	halogen (2), one mounted on boom and one on frame

Undercarriage

Carrier Rollers (per side)	1
Track Rollers (per side)	5
Shoes, Triple Semi-Grouser (per side)	40
Drawbar Pull	14,661 lb. (6650 kg)
Track	
Adjustment	hydraulic
Chain	sealed and lubricated

Swing Mechanism

85D

Swing Speed	10.5 rpm
Swing Torque	12,244 lb.-ft. (16 600 Nm)
Boom Swing	
Left	60 deg.
Right	60 deg.

Ground Pressure

24-in. (600 mm) Triple Semi-Grouser Shoes	3.7 psi (26 kPa)
18-in. (450 mm) Rubber Crawler Pads	4.9 psi (34 kPa)
18-in. (450 mm) Rubber Crawler Belt	4.9 psi (34 kPa)

Serviceability

Refill Capacities

Fuel Tank	35.7 gal. (135 L)
Cooling System	2.7 gal. (10.3 L)
Engine Oil with Filter	3.2 gal. (12.1 L)
Hydraulic Tank	15 gal. (56 L)
Hydraulic System	27 gal. (103 L)
Propel Gearbox (each)	1.3 qt. (1.2 L)

Operating Weights

With Full Fuel Tank; 175-lb. (79 kg) Operator;
0.53-cu.-yd. (0.41 m³), 30-in. (762 mm),
735-lb. (333 kg) Bucket; 5-ft. 4-in. (1.62 m)
Arm; 3,269-lb. (1483 kg) Counterweight;
and 8-ft. 1-in. (2470 mm) Blade

24-in. (600 mm) Triple Semi-Grouser Shoes	18,821 lb. (8537 kg)
18-in. (450 mm) Rubber Crawler Pads	18,490 lb. (8387 kg)
18-in. (450 mm) Rubber Crawler Belt	18,530 lb. (8405 kg)

Optional Components

Undercarriage

24-in. (600 mm) Triple Semi-Grouser Shoes	3,366 lb. (1527 kg)
18-in. (450 mm) Rubber Crawler Pads	3,036 lb. (1377 kg)

One-Piece Boom (with arm cylinder)

1,116 lb. (506 kg)

Arm with Bucket Cylinder and Linkage

5 ft. 4 in. (1.62 m)	608 lb. (276 kg)
6 ft. 11 in. (2.12 m)	661 lb. (300 kg)

Boom Lift Cylinder

196 lb. (89 kg)

Counterweight (standard)

3,269 lb. (1483 kg)

Operating Dimensions

	<i>Arm Length</i> 5 ft. 4 in. (1.62 m)	<i>Arm Length</i> 6 ft. 11 in. (2.12 m)
Arm Force	8,554 lb. (38.1 kN)	7,209 lb. (32.1 kN)
Bucket Digging Force	12,368 lb. (55.0 kN)	12,368 lb. (55.0 kN)
Lifting Capacity Over Front at Ground Level		
20-ft. (6.1 m) Reach	4,248 lb. (1927 kg)	4,151 lb. (1883 kg)
A Maximum Reach	23 ft. 8 in. (7.21 m)	25 ft. 3 in. (7.70 m)
A' Maximum Reach at Ground Level	23 ft. 2 in. (7.05 m)	24 ft. 9 in. (7.55 m)
B Maximum Digging Depth	13 ft. 0 in. (3.97 m)	14 ft. 8 in. (4.47 m)
B' Maximum Digging Depth at 8-ft. (2.44 m) Flat Bottom	11 ft. 10 in. (3.60 m)	13 ft. 9 in. (4.18 m)
C Maximum Cutting Height	22 ft. 4 in. (6.81 m)	23 ft. 7 in. (7.18 m)
D Maximum Dumping Height	15 ft. 9 in. (4.79 m)	16 ft. 10 in. (5.14 m)
E Minimum Swing Radius	9 ft. 0 in. (2.74 m)	9 ft. 6 in. (2.90 m)
F Maximum Vertical Wall	11 ft. 4 in. (3.45 m)	13 ft. 3 in. (4.03 m)
G Tail Swing Radius	4 ft. 3 in. (1.29 m)	4 ft. 11 in. (1.49 m)

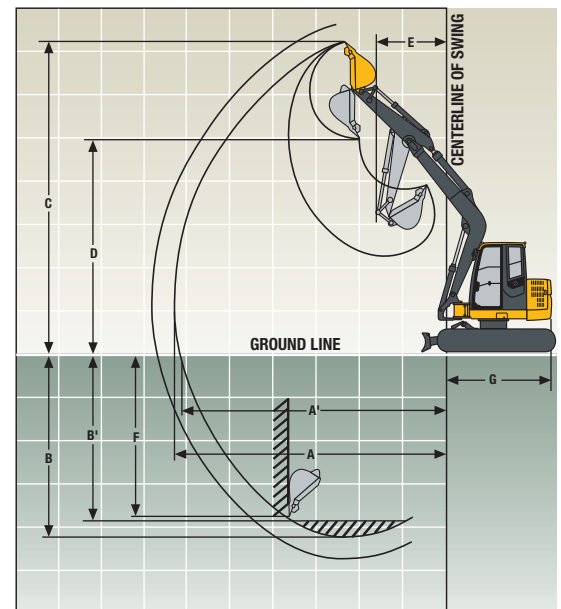

Machine Dimensions

85D

	Arm Length 5 ft. 4 in. (1.62 m)	Arm Length 6 ft. 11 in. (2.12 m)
A Overall Length	22 ft. 0 in. (6.70 m)	22 ft. 4 in. (6.81 m)
B Overall Height	7 ft. 5 in. (2.26 m)	8 ft. 4 in. (2.55 m)
C Overall Width with Blade: 24-in. (600 mm) Triple Semi-Grouser		
Shoes	8 ft. 1 in. (2.47 m)	
Track Height	26 in. (0.65 m)	
18-in. (450 mm) Rubber Crawler Pads	7 ft. 7 in. (2.32 m)	
18-in. (450 mm) Rubber Crawler Belt	7 ft. 7 in. (2.32 m)	
D Rear-End Length/Swing Radius	4 ft. 11 in. (1.49 m)	
E Distance Between Idler/Sprocket Centerline	7 ft. 6 in. (2.29 m)	
F Undercarriage Length	9 ft. 7 in. (2.92 m)	
G Counterweight Clearance	30 in. (0.76 m)	
H Cab Height	8 ft. 10 in. (2.69 m)	
I Ground Clearance	14 in. (360 mm)	
J Upperstructure Width	7 ft. 7 in. (2.32 m)	
K Gauge Width	6 ft. 2 in. (1.87 m)	
L Blade Lift Height	15 in. (380 mm)	
M Blade Cut Below Grade	11 in. (280 mm)	
N Blade Lift Angle	27 deg.	
Blade Height	18 in. (460 mm)	

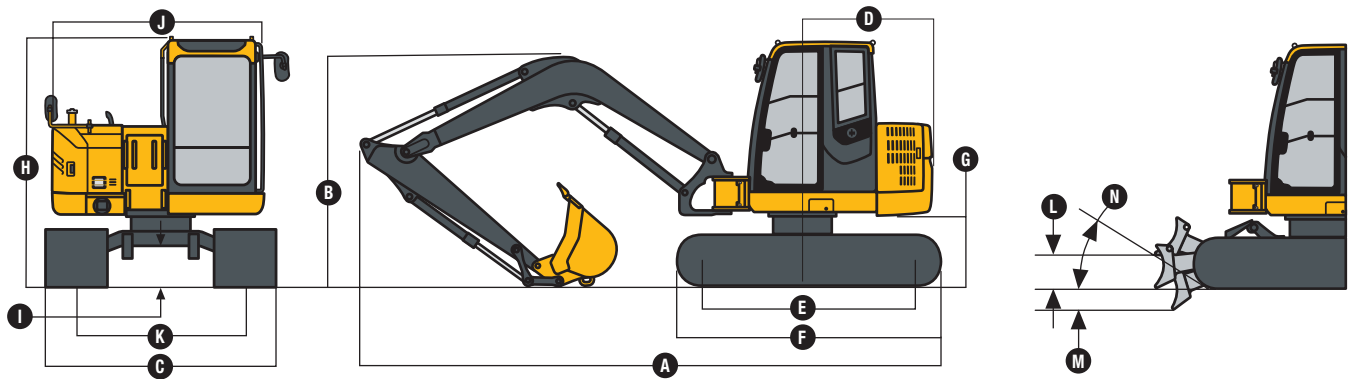

Lift Capacities

Boldface italic type indicates hydraulic-limited capacities; lightface type indicates stability-limited capacities, in lb. (kg). Ratings at bucket lift hook; machine equipped with 12-ft. 2-in. (3.67 m) boom, 0.37-cu.-yd. (0.28 m³) bucket; and situated on firm, uniform supporting surface. Total load includes weight of cables, hook, etc. Figures do not exceed 87 percent of hydraulic capacities or 75 percent of weight needed to tip machine. All lift capacities are based on SAE J1097.

Load Point Height	10 ft. (3.05 m)		15 ft. (4.57 m)		20 ft. (6.10 m)	
	Over Front	Over Side	Over Front	Over Side	Over Front	Over Side
<i>With 5-ft. 4-in. (1.62 m) arm, either 18-in. (450 mm) rubber crawler pads or 18-in. (450 mm) rubber crawler belt, and 7-ft. 7-in. (2.32 m) blade on ground</i>						
15 ft. (4.57 m)			3,595 (1631)	3,446 (1563)		
10 ft. (3.05 m)			4,176 (1894)	3,311 (1502)	3,525 (1599)	1,978 (897)
5 ft. (1.52 m)			5,540 (2513)	3,018 (1369)	3,959 (1796)	1,895 (860)
Ground Line			6,247 (2834)	2,822 (1280)	4,167 (1890)	1,813 (822)
-5 ft. (-1.52 m)	6,326 (2869)	5,393 (2446)	5,703 (2587)	2,796 (1268)		
<i>With 6-ft. 11-in. (2.12 m) arm, either 18-in. (450 mm) rubber crawler pads or 18-in. (450 mm) rubber crawler belt, and 7-ft. 7-in. (2.32 m) blade on ground</i>						
10 ft. (3.05 m)			3,604 (1635)	3,429 (1555)	3,304 (1499)	2,069 (938)
5 ft. (1.52 m)			5,117 (2321)	3,155 (1431)	3,772 (1711)	1,973 (895)
Ground Line			6,219 (2821)	2,931 (1329)	4,179 (1896)	1,876 (851)
-5 ft. (-1.52 m)	8,733 (3961)	5,452 (2473)	6,117 (2775)	2,861 (1298)	3,989 (1809)	1,841 (835)
-10 ft. (-3.05 m)	6,901 (3130)	5,593 (2537)	4,473 (2029)	2,926 (1327)		

Lift Capacities (continued)

85D

Boldface italic type indicates hydraulic-limited capacities; lightface type indicates stability-limited capacities, in lb. (kg). Ratings at bucket lift hook; machine equipped with 12-ft. 2-in. (3.67 m) boom, 0.37-cu.-yd. (0.28 m³) bucket; and situated on firm, uniform supporting surface. Total load includes weight of cables, hook, etc. Figures do not exceed 87 percent of hydraulic capacities or 75 percent of weight needed to tip machine. All lift capacities are based on SAE J1097.

Load Point Height	10 ft. (3.05 m)		15 ft. (4.57 m)		20 ft. (6.10 m)	
	Over Front	Over Side	Over Front	Over Side	Over Front	Over Side
<i>With 5-ft. 4-in. (1.62 m) arm, 24-in. (600 mm) triple semi-grouser shoes, and 8-ft. 1-in. (2.47 m) blade on ground</i>						
15 ft. (4.57 m)			3,595 (1631)	3,534 (1603)		
10 ft. (3.05 m)			4,176 (1894)	3,399 (1542)	3,525 (1599)	2,040 (925)
5 ft. (1.52 m)			5,540 (2513)	3,106 (1409)	3,959 (1796)	1,957 (888)
Ground Line			6,247 (2834)	2,910 (1320)	4,167 (1890)	1,875 (850)
-5 ft. (-1.52 m)	6,326 (2869)	5,545 (2515)	5,703 (2587)	2,884 (1308)		
<i>With 6-ft. 11-in. (2.12 m) arm, 24-in. (600 mm) triple semi-grouser shoes, and 8-ft. 1-in. (2.47 m) blade on ground</i>						
10 ft. (3.05 m)			3,604 (1635)	3,441 (1561)	3,304 (1499)	2,077 (942)
5 ft. (1.52 m)			5,117 (2321)	3,167 (1437)	3,772 (1711)	1,981 (899)
Ground Line			6,219 (2821)	2,942 (1334)	4,179 (1896)	1,885 (855)
-5 ft. (-1.52 m)	8,733 (3961)	5,472 (2482)	6,117 (2775)	2,873 (1303)	3,989 (1809)	1,849 (839)
-10 ft. (-3.05 m)	6,901 (3130)	5,613 (2546)	4,473 (2029)	2,938 (1333)		

Buckets

A full line of buckets is offered to meet a wide variety of applications. Tooth selection includes either the John Deere Fanggs®, Standard, Tiger, Twin Tiger, Abrasion panel, or Flare tooth, or the ESCO (Vertalok) Standard, Tiger, Twin Tiger, or Flare tooth. Replaceable cutting edges are available through John Deere parts. Optional side cutters add 6 inches (150 mm) to bucket widths.

Type Bucket	Bucket Width		Bucket Capacity*		Weight		Bucket Dig Force		Arm Dig Force 5 ft. 4 in. (1.62 m)		Arm Dig Force 6 ft. 11 in. (2.12 m)		Bucket Tip Radius		No. Teeth
	in.	mm	cu. yd.	m ³	lb.	kg	lb.	kN	lb.	kN	lb.	kN	in.	mm	
Heavy-Duty	24	610	0.40	0.31	633	287	12,061	54.0	8,491	38.0	7,162	32.0	42.80	1087	5
	30	762	0.53	0.41	735	333	12,061	54.0	8,491	38.0	7,162	32.0	42.80	1087	6
	36	914	0.66	0.50	837	380	12,061	54.0	8,491	38.0	7,162	32.0	42.80	1087	7
Ditching	48	1219	0.64	0.49	727	330	14,344	64.0	8,911	40.0	7,473	33.0	35.69	907	0

*All capacities are SAE heaped ratings.

Bucket Selection Guide*

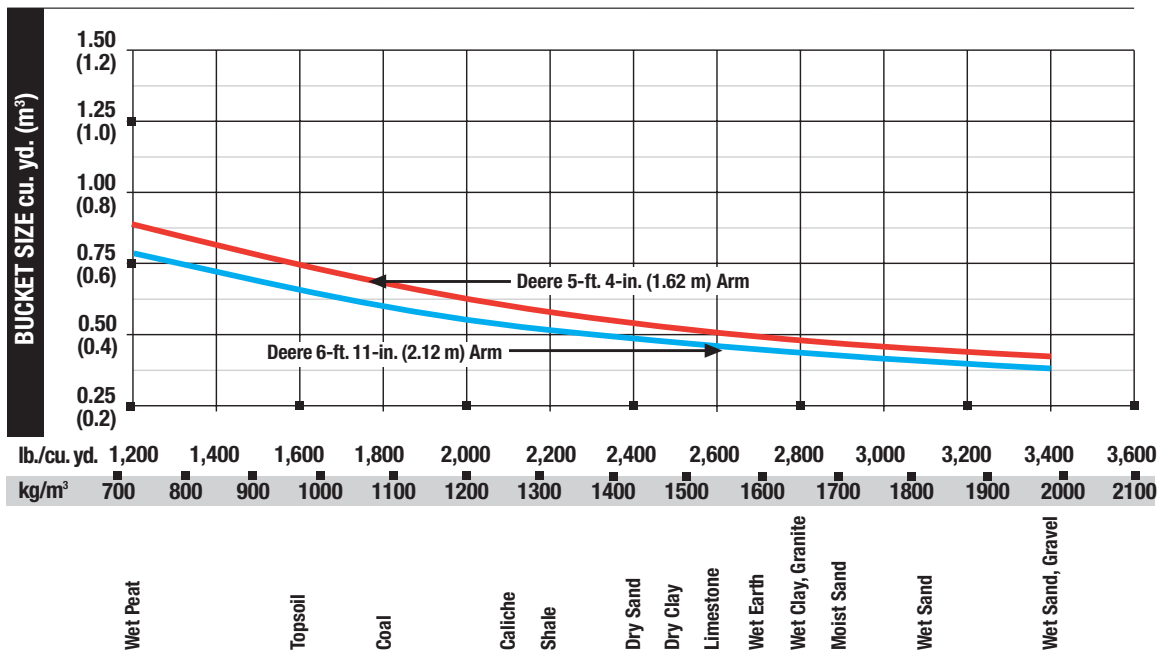

*Contact your John Deere dealer for optimum bucket and attachment selections. These recommendations are for general conditions and average use. Does not include optional equipment such as thumbs or couplers. Larger buckets may be possible when using light materials, for flat and level operations, less compacted materials, and volume loading applications such as mass excavation applications in ideal conditions. Smaller buckets are recommended for adverse conditions such as off-level applications, rocks, and uneven surfaces. Bucket capacity indicated is SAE heaped.

75D / 85D EXCAVATORS

Key: ● Standard equipment ▲ Optional or special equipment

See your John Deere dealer for further information.

75D	85D	Engine	75D	85D	Undercarriage (continued)	75D	85D	Operator's Station (continued)
●	●	Certified to EPA interim Tier 4 emissions	●	●	Undercarriage with blade	●	●	Hydraulic warm-up control
●	●	Auto-idle system	▲	▲	Rubber crawler pads, 18-in. (450 mm)	●	●	Interior light
●	●	Batteries (two 12 volt), 100-min. reserve capacity	▲	▲	Rubber belt, continuous, 18-in. (450 mm)	●	●	Large cup holder
●	●	Coolant recovery tank	Upperstructure			●	●	Machine Information Center (MIC)
●	●	Dual-element dry-type air filter	●	●	Counterweight, 3,049 lb. (1,383 kg)	●	●	Mode selectors (illuminated): Power modes – two / Travel modes – two with automatic shift / Work mode – one
●	●	Electronic engine control	●	●	Counterweight, 3,269 lb. (1,483 kg)	●	●	Multifunction, color LCD monitor with: Diagnostic capability / Multiple-language capabilities / Maintenance tracking / Clock / System monitoring with alarm features: Auto-idle indicator, engine air cleaner restriction indicator light, engine check, engine coolant temperature indicator light with audible alarm, engine oil pressure indicator light with audible alarm, low-alternator-charge indicator light, low-fuel indicator light, fault-code alert indicator, fuel-rate display, wiper-mode indicator, work-lights-on indicator, and work-mode indicator
●	●	Enclosed fan guard (conforms to SAE J1308)	●	●	Right- and left-hand mirrors	●	●	Motion alarm with cancel switch (conforms to SAE J994)
●	●	Engine coolant to -34 deg. F (-37 deg. C)	●	●	Vandal locks with ignition key: Cab door / Engine hood / Fuel cap / Service doors	●	●	Auxiliary hydraulic control switches in right console lever
●	●	Fuel filter with water separator	●	●	Remote-mounted engine oil and fuel filters	●	●	SAE two-lever control pattern
●	●	Full-flow oil filter	Front Attachments			●	●	Seat belt, 2 in. (51 mm), retractable
●	●	Turbocharger with charge air cooler	●	●	Centralized lubrication system	●	●	Tinted glass
●	●	Muffler, under hood, with vertical curved end exhaust stack	●	●	Dirt seals on all bucket pins	●	●	Transparent tinted overhead hatch
●	●	Radiator, oil cooler, and intercooler with dust-protective net	●	●	Less boom and arm	●	●	Transparent tinted overhead window
●	●	Glow-plug start aid	●	●	Oil-impregnated bushings	●	●	Hot/cold beverage compartment
●	●	500-hour engine oil-change interval	●	●	Reinforced resin thrust plates	●	●	Seat belt, 3 in. (76 mm), non-retractable
●	●	70% (35 deg.) off-level capacity	●	●	Tungsten carbide thermal coating on arm-to-bucket joint	▲	▲	Monitor system with alarm features: Hydraulic oil filter restriction indicator light
●	●	Isolation mounted	▲	▲	Arm, 5 ft. 4 in. (1.62 m)	▲	▲	24- to 12-volt D.C. radio converters, 10 amp
●	●	Engine oil-drain coupler	▲	▲	Arm, 6 ft. 11 in. (2.12 m)	▲	▲	Circulation fan
Hydraulic System			▲	▲	Attachment quick-couplers	▲	▲	Protection screens for cab front, rear, and side
●	●	Reduced-drift valve for boom down, arm in	▲	▲	Buckets: Ditching / Heavy duty / Heavy-duty high capacity / Side cutters and teeth	▲	▲	Window vandal protection covers
●	●	Auxiliary hydraulic valve section	▲	▲	Material clamps	Electrical		
●	●	Spring-applied, hydraulically released automatic swing brake	●	●	Operator's Station	●	●	50-amp alternator
●	●	Auxiliary hydraulic-flow adjustments through monitor	●	●	Adjustable independent control positions (seat-to-pedals)	●	●	Blade-type multi-fused circuits
●	●	5,000-hour hydraulic oil-change interval	●	●	AM/FM radio	●	●	Positive terminal battery covers
▲	▲	Auxiliary hydraulic lines	●	●	Auto climate control/air conditioner, 20,000 Btu/hr. (5.9 kW), with heater and pressurizer	●	▲	JDLink™ wireless communication system
▲	▲	Auxiliary pilot and electric controls	●	●	Built-in operator's manual storage compartment and manual	●	Lights	
▲	▲	Hydraulic filter restriction indicator kit	●	●	Cell-phone power outlet, 12 volt, 60 watt, 5 amp	●	●	Work lights: Halogen / One mounted on boom / One mounted on frame
▲	▲	Load-lowering control device	●	●	Coat hook	●		
▲	▲	Single-pedal propel control	●	●	Deluxe suspension cloth seat with 4-in. (100 mm) adjustable armrests	●		
▲	▲	Control pattern-change valve	●	●	Deluxe suspension cloth seat with 3-in. (76 mm) adjustable armrests	●		
Undercarriage			●	●	Floor mat	●		
●	●	Planetary drive with axial piston motors	●	●	Front windshield wiper with intermittent speeds	●		
●	●	Propel motor shields	●	●	Gauges (illuminated): Engine coolant / Fuel	●		
●	●	Spring-applied, hydraulically released automatic propel brake	●	●	Horn, electric	●		
●	●	Track guides, front idler	●	●	Hour meter, electric	●		
●	●	Two-speed propel with automatic shift	●	●	Hydraulic shutoff lever, all controls			
●	●	Upper carrier roller (1)						
●	●	Sealed and lubricated track chain						
●	●	Triple semi-grouser shoes, 24 in. (600 mm)						

CONTROL OWNING AND OPERATING COSTS

Customer Personal Service (CPS) is part of John Deere's proactive, fix-before-fail strategy on machine maintenance that will help control costs, increase profits, and reduce stress. Included in this comprehensive lineup of ongoing programs and services are:

Fluid analysis program – tells you what's going on inside *all* of your machine's major components so you'll know if there's a problem *before* you see a decline in performance. Fluid analysis is included in most extended coverage and preventive-maintenance agreements.

Component life-cycle data – gives you vital information on the projected life span of components and lets you make informed decisions on machine maintenance by telling you approximately how many hours of use you can expect from an engine, transmission, or hydraulic pump. This information can be used to preempt catastrophic downtime by servicing major components at about 80 percent of their life cycle.

Preventive Maintenance (PM) agreements – give you a fixed cost for maintaining a machine for a given period of time. They also help you avoid downtime by ensuring that

critical maintenance work gets done right and on schedule. On-site preventive maintenance service performed where and when you need it helps protect you from the expense of catastrophic failures and lets you avoid waste-disposal hassles.

Extended coverage – gives you a fixed cost for machine repairs for a given period of time so you can effectively manage costs. Whether you work in a severe-service setting or just want to spread the risk of doing business, this is a great way to custom-fit coverage for your operation. And an extended coverage contract also travels well because it's backed by John Deere and is honored by *all* Deere construction dealers.

Customer Support Advisors (CSAs) – Deere believes the CSA program lends a *personal* quality to Customer Personal Service (CPS). Certified CSAs have the knowledge and skills for helping make important decisions on machine maintenance and repair. Their mission is to help you implement a plan that's right for *your* business and take the burden of machine maintenance off your shoulders.



JOHN DEERE

DKAX75D85D Litho in U.S.A. (08-08)

Net engine power is with standard equipment including air cleaner, exhaust system, alternator, and cooling fan at test conditions specified per ISO9249. No derating is required up to 10,000-ft. (3050 m) altitude.

Specifications and design subject to change without notice. Wherever applicable, specifications are in accordance with SAE standards. Except where otherwise noted, these specifications are based on a unit with standard equipment; 0.53-cu.-yd. (0.41 m³), 30-in. (762 mm), 735-lb. (333 kg) bucket; 24-in. (600 mm) triple semi-grouser shoes; 5-ft. 4-in. (1.62 m) arm; full fuel tank; and 175-lb. (79 kg) operator; a 75D unit with 3,049-lb. (1,383 kg) counterweight; and an 85D unit with 3,269-lb. (1,483 kg) counterweight.

