

7 7 - 9 9 N E T H O R S E P O W E R



**JOHN DEERE**

J

**DOZERS**

450J | 550J | 650J





## 650J

99 hp LT, XLT, and LGP  
18,560 lb. LT  
18,600 lb. XLT  
19,750 lb. LGP  
18-, 20-, 24-, and 28-in. grousers  
105-, 115-, and 128-in. blades

# Push productivity

Often imitated but never duplicated, John Deere dozers continue to set the standard for operator control and productivity. Backed by 30 years of hydrostatic experience, their unique state-of-the-art Total Machine Control (TMC) enables an operator to customize machine operation and response to

personal preferences. Coupled with an uncommonly smooth full-featured hydrostatic transmission, the J-Series deliver unsurpassed productivity, uptime, and daily operating costs. That's for starters. Read on and learn more about all of the J-Series Dozers' many productivity- and uptime-boosting advantages.

## 550J

85 hp LT and LGP  
17,016 lb. LT  
18,252 lb. LGP  
18- and 24-in. grousers  
105-, 115-, and 124-in. blades

## 450J

77 hp LT, and LGP  
16,283 lb. LT  
17,525 lb. LGP  
16-, and 24-in. grousers  
97-, 115-, and 124-in. blades



# to the next level.

Operator-favorite speed-in-grip steering and transmission control lever and rotary throttle are standard equipment.

Decelerator lets you choose between slowing travel speed and engine rpm, or travel speed only. For unparalleled low-effort toe-tip control.

Deere's unique TMC lets an operator customize the crawler's operating characteristics and response, and even records machine usage.

Extended service intervals, larger fuel tanks, remote test ports, and diagnostic messaging help maximize uptime and productivity.

Tier 3 emission-certified diesels deliver power without compromise in all conditions.



Counterrotation is a productivity-boosting feature that enables the operator to overcome heavy corner loads and to quickly reposition the blade on the go. Provides space-saving spot turns, too.



With optional Integrated Grade Control (IGC), your 650J Dozer arrives from the factory "plug and play" ready. Its open architecture design lets you employ the electronic grade-control system that's right for you.



These dozers steer the same and maintain their preset speed whether they're on level ground or a 2-to-1 slope. For total control regardless of the terrain.

# Uncommon control, uncompromising results.

Others may offer hydrostatic drivetrains in their dozers. But no other dozer even comes close to delivering the proven performance and exceptionally smooth control you get with the 450J, 550J, or 650J. Power turns, counterrotation, infinitely variable travel speeds – the J-Series'

enhanced state-of-the-art controls put you in complete command of a whole arsenal of highly productive hydrostatic advantages. No wonder John Deere finish dozers have become owner and operator favorites. And why they continue to deliver industry-leading resale value.

State-of-the-art controls command the full-featured hydrostatic drivetrain and six-way blade, ensuring predictable response at all times, in all conditions.

Power management takes the guesswork out of efficient operation. Simply set maximum desired ground speed and the system maintains peak engine and power efficiency without stalling or shifting.

Infinitely variable travel speeds from standstill to five mph let an operator choose the right speed for the job. Travel-speed range can also be modified for specific applications or terrain conditions, and even limited to maximize undercarriage life.

Blade ratio and center of gravity are optimized, giving these dozers the balance needed for superior grade work.

TMC allows maximum flexibility and control, letting you customize machine operation to personal preferences.



Infinitely variable control lets an operator speed up or slow power to each track, for smooth, full-power turns.

The fully modulated drivetrain ensures smooth starts and direction changes—virtually eliminating jerky and abrupt movements.

The image shows the operator's seat and control area of a skid steer loader. The seat is upholstered in grey fabric and has a black seat belt. To the left of the seat is a black T-bar control lever. To the right is a steering wheel with a red ball-top. In the background, there is a white and red cooler and a blue thermos. The text "Get more done within our comfort zone." is overlaid in white with a black outline.

# Get more done within our comfort zone.

Generous hydraulic flow and precise metering deliver a natural "feel" to the T-bar control that will enhance any operator's grading skills. Blade response is powerful and quick.

Retractable seat belt, slip-resistant floor mat, convenient grab bars, neutral-start lever, and automatic park brake help keep the operator out of harm's way.

Deluxe-suspension armchair adjusts seven ways for daylong comfort and support. Adjustable armrests and footrests are standard.

Single lever provides low-effort control of steering, forward/reverse travel, and ground speed. It's also detented so it doesn't require an operator's constant touch or attention and employs a thumb-actuated travel-speed switch.

Convenient 12-volt port provides power for cell phones and other accessories.

Want your operators to be more productive? Put them in the seat of this spacious air-conditioned cab. From their ergonomically designed fully customizable controls to best-in-class visibility, J-Series Dozers are loaded with everything you need to keep your operators calm, cool, productive – and on the payroll.



Cab-forward design positions the operator for a more stable ride and a commanding view behind, below, and beyond the blade. Monitor keeps a vigilant watch on vital functions and issues visual or audible warnings.



Exclusive TMC lets you customize decelerator mode and response, forward/reverse ground-speed ranges, steering modulation, FNR shift rate, and forward/reverse speed ratios, for unsurpassed control.



Choose the decelerator function that's right for the job. Slow both ground speed and engine rpm, or ground speed only to help maintain traction without affecting engine power and hydraulic response. Fully depressing the pedal applies the brakes.



Automotive-type directional vents deliver warm or cool air with quiet efficiency. Air conditioning is standard in all cabs. For non-cab crawlers, an optional under-seat heater warms the operator.



High-intensity halogen driving lights are standard. Or opt for the factory-installed 360-degree light package that delivers superior illumination.

Engine, hydrostatic pumps, and hydraulic pump are bolted to a subframe, forming an easy-to-remove powertrain package. It's attached to the mainframe on rubber mounts to isolate vibration and reduce noise.

One-piece robot-welded mainframe resists torsional stress, absorbs shock loads, and delivers maximum strength while providing easy service access to major drivetrain components.

Wet sleeve liners provide uniform engine cooling and longer durability than cast-in-block designs.

Heavy-duty high-pressure hoses connect the pumps and motors that form the drivetrain. O-ring face-seal couplings virtually eliminate leaks.



# Nothing runs like a Deere, because nothing is built like one.

Designed and built with state-of-the-art tools and techniques by a quality-conscious workforce at our world-class facility in Dubuque, Iowa, Deere dozers deliver unsurpassed reliability and uptime.

But don't just take our word for it. Perhaps the best way to know what you can expect out of one is to see what goes into it. When you learn how they're built, you'll run a Deere.

Heavy-duty triple-reduction final drives are attached to the mainframe, isolating them from track-imposed shock loads. Seal guards are built in, not extra cost.

Sealed transmission electrical connectors with gold-plated pins prevent moisture and contaminants from entering terminals for increased reliability.

Standard features such as bypass start protection, automatic park brake, convenient handholds, and slip-resistant steps help keep the operator out of harm's way.

Closed-cell blade design and robot-welded, fabricated, box-section C-frame is strong and durable. Heavy-duty ball-and-socket joint resists material build-up for long-term grading precision.



Standard undercarriage is sealed, lubricated, and built to last. Available SC-2 extended life track chain delivers up to twice the bushing life. For reduced operating costs in extremely abrasive conditions, choose the Maximum-Life undercarriage system — and get all of the SC-2 advantages, plus larger track rollers, carrier rollers, idlers, and seals.

Large fuel tanks and 500-hour engine oil service intervals let you run longer between fill-ups and maintenance.

# The bucks stop here.

Hinged side shields open wide and provide ground-level access to batteries; master electrical switch; cold-weather-start aid; and vertical transmission, hydraulic, and fuel filters.



Unlike other crawlers that require a laptop computer, an advanced diagnostic monitor gives easy-to-understand messages.



Vertical filters allow quick, no-spill changes. Engine, hydraulics, and transmission utilize a common oil, further simplifying service.



Serpentine belt never needs adjusting. 500-hour service interval lets you go longer between engine oil changes.



Remote drive system test ports help speed troubleshooting for increased uptime and productivity.

If there's a way to reduce your daily operating costs and simplify maintenance, we've incorporated it into the J-Series Dozers. Service intervals have been extended, and same-side service points help make quick work of the daily routine. Lockable doors swing open wide, providing quick

and ample access to dipsticks, vertical spin-on filters, sight gauges, and maintenance-free batteries. These and other timesaving features such as an easy-to-clean undercarriage, quick-to-replace hydraulic hoses, and designed-in diagnostics minimize downtime and expense.



Hydraulic and hydrostatic reservoirs are completely separated, eliminating any possibility of cross-contamination.

With JDLink™, you'll know exactly where your dozer is and how it's performing. This optional wireless communication system delivers location, utilization, performance, and maintenance data to your computer. Helps increase productivity and uptime, and lower operating costs.

Lube bank puts difficult-to-grease C-frame pivots within easy reach. Periodic maintenance and lube chart ensures that nothing gets overlooked.



# Specifications

<b>Engine</b>	<b>450J LT / 450J LGP</b>
Manufacturer and Model	John Deere 4045H
Non-Road Emission Standards	certified to EPA Tier 3 emissions
Cylinders	4
Displacement	276 cu. in. (4.5 L)
SAE Net Rated Power @ 2,200 rpm	77 hp (57 kW)
Net Peak Torque @ 1,200 rpm	251 lb.-ft. (341 Nm)
Aspiration	altitude-compensating turbocharger with charge air cooler
Air Cleaner	dual safety element dry type, evacuator valve
Slope Operation (maximum angle)	45 deg.

<b>Cooling</b>	
Blower-type cooling fan	
Engine Coolant Rating	-34 deg. F (-37 deg. C)
Engine Radiator	10 fins per in.
Hydrostatic Cooler and Hydraulic Cooler (oil/air)	10 fins per in.
Charge Air Cooler (air/air)	10 fins per in.

<b>Powertrain</b>	
<b>Transmission</b>	dual-path, electronic-controlled, hydrostatic drive; load-sensing, automatically adjusts speed and power to match changing load conditions; each track is powered by a variable-displacement piston pump and two-speed motor combination; decelerator controls speed; transmission neutral lock with safety start switch
Travel Speeds (forward and reverse)	0-5.0 mph (0-8.0 km/h)
<b>Steering</b>	single-lever steering, direction control, and counterrotation; full power turns and infinitely variable track speeds provide unlimited maneuverability and optimum control; hydrostatic steering eliminates steering clutches and brakes
<b>Final Drives</b>	heavy-duty triple-reduction final drives attach directly to the mainframe; isolated from track and dozer frame loads
<b>Brakes</b>	hydrostatic (dynamic) braking stops the machine whenever the direction-control lever is moved to neutral or whenever the decelerator is depressed to the detent
<b>Service Brakes</b>	hydrostatic braking when direction-control lever is moved to neutral or when the decelerator is depressed to the detent
<b>Parking Brakes</b>	wet, multi-disc applied automatically when engine stops, when decelerator pedal depressed to brake position, when unit is in neutral for three seconds with detected motion, or when the park lock lever is in park position; machine cannot be driven with brake applied

<b>Hydraulics</b>	
Open-center hydraulic system with gear pump	
Pump Flow @ 2,200 rpm	15 gpm (56.8 L/min.)
System Relief Pressure	3,000 psi (20 684 kPa)
Controls	3-function hydraulic valve with low-effort single-lever T-bar

<b>Electrical</b>	
Voltage	12 volt
Battery Capacity	950 CCA
Reserve Capacity	190 min.
Alternator Rating	65 amp
<b>Standard Lights</b>	3 total: grille mounted (2) and rear mounted (1), and rear reflectors (2)

Undercarriage	450J LT	450J LGP
Tracks	John Deere Dura-Trax™, deep-heat-treated, pins and bushings sealed for life; rollers and idlers permanently sealed and lubricated	John Deere Dura-Trax, deep-heat-treated, pins and bushings sealed for life; rollers and idlers permanently sealed and lubricated
Track Gauge (standard)	4 ft. 9 in. (1448 mm)	5 ft. 5 in. (1651 mm)
Grouser Width (closed center, single bar)	16 in. (406 mm)	24 in. (610 mm)
Chain	sealed and lubricated	sealed and lubricated
Shoes (each side)	40	40
Track Rollers (single flange, each side)	6	6
<b>Undercarriage Track</b>	<i>Standard</i>	<i>Standard</i>
Track Length on Ground	7 ft. 2 in. (2184 mm)	7 ft. 1 in. (2154 mm)
Ground Contact Area	2,752 sq. in. (17 755 cm <sup>2</sup> )	2,710 sq. in. (17 484 cm <sup>2</sup> )
Ground Pressure	5.9 psi (40.7 kPa)	6.1 psi (42.3 kPa)
Track Pitch	6.29 in. (160 mm)	6.73 in. (171 mm)
	<i>Maximum Life</i>	<i>Maximum Life</i>
	7 ft. 1 in. (2154 mm)	7 ft. 1 in. (2154 mm)
	4,710 sq. in. (26 632 cm <sup>2</sup> )	4,070 sq. in. (26 258 cm <sup>2</sup> )
	4.3 psi (29.3 kPa)	4.37 psi (30.1 kPa)
	6.29 in. (160 mm)	6.73 in. (171 mm)

Serviceability	450J LT / 450J LGP
<b>Refill Capacities</b>	
Fuel Tank	47 gal. (178 L)
Cooling System with Recovery Tank	17 qt. (16 L)
Engine Oil with Filter	15 qt. (14 L)
Transmission Reservoir with Filter	11.3 gal. (43 L)
Final Drive (each)	7 qt. (6.6 L)
Hydraulic Reservoir and Filter	8.5 gal. (32.2 L)

Operating Weights	450J LT	450J LGP
With Full Fuel Tank, 175-lb. (79 kg) Operator, ROPS, and Standard Equipment		
97-in. (2464 mm) Blade and 16-in. (406 mm) Track Shoes	16,283 lb. (7386 kg)	
124-in. (3150 mm) Blade and 24-in. (610 mm) Track Shoes		17,525 lb. (7949 kg)
<b>Optional Components</b>		
Maximum Life Undercarriage	290 lb. (132 kg)	290 lb. (132 kg)
Rock Guards (4)	257 lb. (117 kg)	288 lb. (131 kg)
For Maximum Life Undercarriage	193 lb. (88 kg)	193 lb. (88 kg)
Cab	675 lb. (306 kg)	675 lb. (306 kg)
<b>Counterweight</b>		
Rear (each)	330 lb. (150 kg)	330 lb. (150 kg)
Front (each)	240 lb. (109 kg)	240 lb. (109 kg)
Retrieval Hitch	50 lb. (23 kg)	50 lb. (23 kg)
Extended Drawbar	72 lb. (33 kg)	72 lb. (33 kg)
Limb Risers	229 lb. (104 kg)	229 lb. (104 kg)
<b>Screens</b>		
Rear	76 lb. (34 kg)	76 lb. (34 kg)
Side	94 lb. (43 kg)	94 lb. (43 kg)
Front and Doors	179 lb. (81 kg)	179 lb. (81 kg)
<b>Winch</b>		
4000S	1,437 lb. (652 kg)	1,437 lb. (652 kg)
Fairlead, 4-Roller	187 lb. (85 kg)	187 lb. (85 kg)
Ripper, Parallelogram	2,163 lb. (981 kg)	2,163 lb. (981 kg)
97-in. (2464 mm) Blade, All-Hydraulic Heavy-Duty C Frame	96 lb. (44 kg)	
115-in. (2921 mm) Blade, All-Hydraulic Heavy-Duty C Frame (adjust to base weight)		5 lb. (2 kg)
All-Hydraulic Heavy-Duty C Frame (less blade; adjust to base weight)	- 1,063 lb. (- 482 kg)	- 1,063 lb. (- 482 kg)

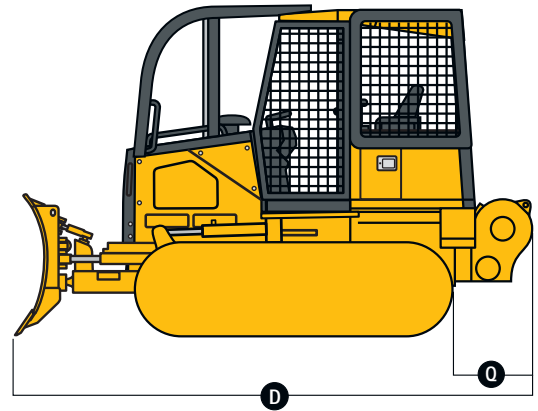
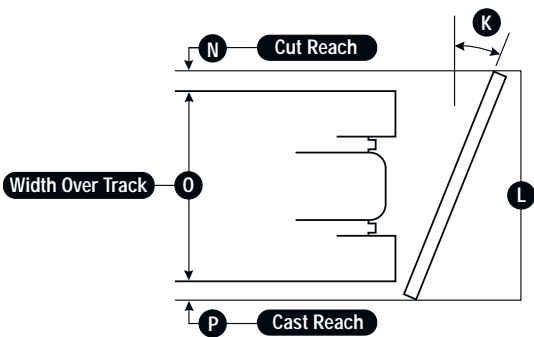
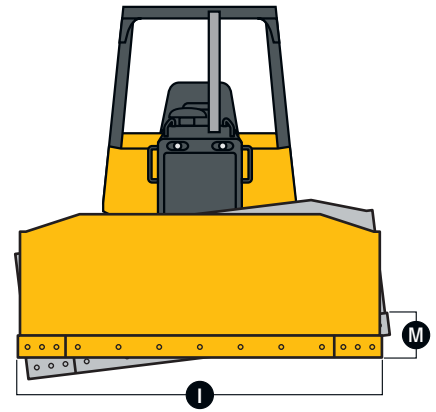
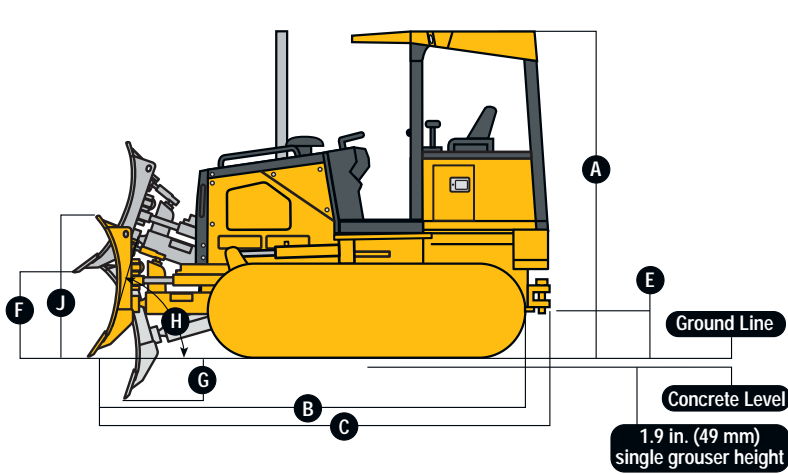

**Machine Dimensions**

**450J LT**

**450J LGP**

<b>A</b> Overall Height (ROPS or cab) . . . . .	9 ft. 0 in. (2.74 m)	9 ft. 0 in. (2.743 m)
Height of Grousers . . . . .	1.9 in. (48.3 mm)	1.9 in. (48 mm)
<b>B</b> Overall Length . . . . .	12 ft. 11 in. (3.94 m)	13 ft. 2 in. (4013 mm)
<b>C</b> Overall Length with Extended Drawbar . . . . .	13 ft. 6 in. (4.11 m)	13 ft. 4 in. (4064 mm)
<b>D</b> Overall Length with Winch . . . . .	14 ft. 9 in. (4.50 m)	14 ft. 9 in. (4496 mm)
<b>E</b> Ground Clearance with Single-Bar Grouser (excluding grouser height) . . . . .	13.6 in. (345 mm)	13.6 in. (345 mm)
<b>F</b> Blade Lift Height . . . . .	30.4 in. (772 mm)	30.4 in. (772 mm)
<b>G</b> Blade Digging Depth . . . . .	20.8 in. (528 mm)	20.8 in. (528 mm)
<b>H</b> Blade Cutting Edge Angle (adjustable) . . . . .	52 to 60 deg.	52 to 60 deg.

**Blade Specs**

<b>I</b> Width . . . . .	97 in. (2464 mm)	115 in. (2921 mm)	115 in. (2921 mm)	124 in. (3150 mm)
<b>J</b> Height . . . . .	3 ft. 2 in. (955 mm)	3 ft. 2 in. (955 mm)	3 ft. 2 in. (955 mm)	2 ft. 11 in. (894.1 mm)
SAE Capacity . . . . .	2.14 cu. yd. (1.64 m <sup>3</sup> )	2.57 cu. yd. (1.96 m <sup>3</sup> )	2.57 cu. yd. (1.96 m <sup>3</sup> )	2.46 cu. yd. (1.88 m <sup>3</sup> )
<b>K</b> Blade Angle . . . . .	25.4 deg.	25.4 deg.	25.4 deg.	25.4 deg.
<b>L</b> Angled Width . . . . .	7 ft. 4 in. (2225 mm)	8 ft. 8 in. (2639 mm)	8 ft. 8 in. (2639 mm)	9 ft. 4 in. (2845 mm)
<b>M</b> Tilt . . . . .	13.3 in. (338 mm)	15.7 in. (399 mm)	15.7 in. (399 mm)	16.9 in. (429 mm)
<b>N</b> Cut Reach . . . . .	2.2 in. (56 mm)	10.3 in. (262 mm)	2.3 in. (58.4 mm)	6.4 in. (163 mm)
<b>O</b> Width Over Track . . . . .	6 ft. 1 in. (1854 mm)	6 ft. 1 in. (1854 mm)	7 ft. 5 in. (2261 mm)	7 ft. 5 in. (2261 mm)
<b>P</b> Cast Reach . . . . .	12.5 in. (318 mm)	20.6 in. (523 mm)	12.6 in. (320 mm)	17 in. (424 mm)

## Rear Ripper

## 450J LT / 450J LGP

<b>Q</b>	4000S Winch Length	30 in. (752 mm)
<b>R</b>	Maximum Penetration	20 in. (508 mm)
<b>S</b>	Maximum Clearance Under Tip	20 in. (508 mm)
<b>T</b>	Overall Length (lowered position)	57 in. (1450 mm)
<b>T'</b>	Overall Length (raised position)	40 in. (1015 mm)
<b>U</b>	Overall Beam Width	72 in. (1830 mm)
<b>V</b>	Slope Angle (full raise)	40 deg.
<b>W</b>	Ripping Width	66 in. (1670 mm)
<b>X</b>	Distance Between Shanks (3 installed)	32 in. (806 mm)
	Distance Between Holes In 2-Position Shank	3.1 in. (80 mm)

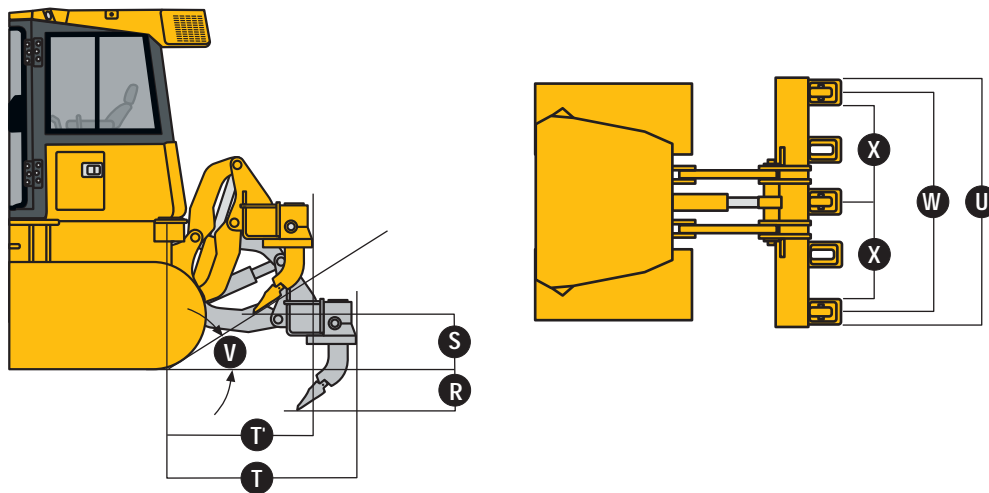

## Drawbar Pull

Crawler Speed vs Ground Pull . . . . . usable pull will depend on traction and weight of tractor

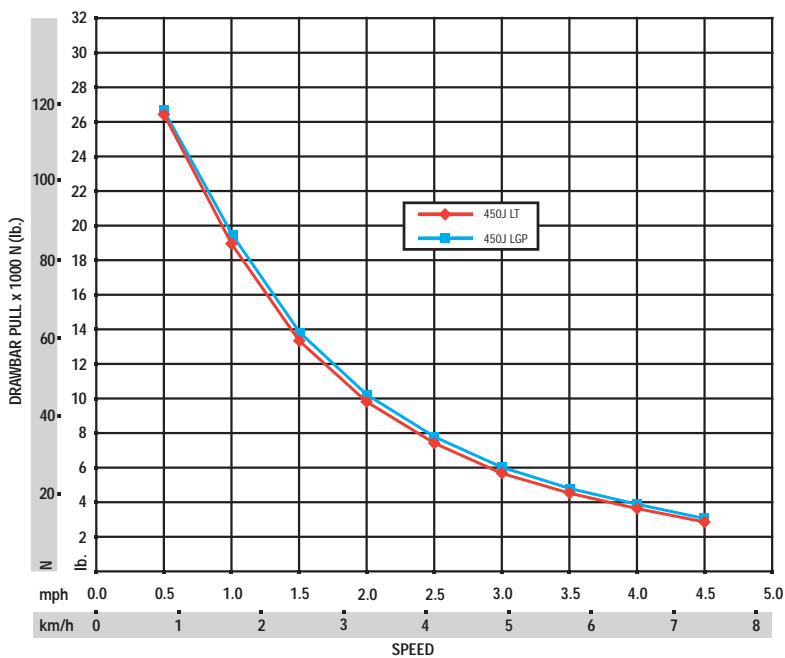

# Specifications

## Engine 550J LT / 550J LGP

Manufacturer and Model	John Deere 4045H
Non-Road Emission Standards	certified to EPA Tier 3 emissions
Cylinders	4
Displacement	276 cu. in. (4.5 L)
SAE Net Rated Power @ 2,200 rpm	85 hp (63 kW)
Net Peak Torque @ 1,200 rpm	276 lb.-ft. (375 Nm)
Engine Bore and Stroke	4.19 x 5.0 in. (106.5 x 127 mm)
Aspiration	altitude-compensating turbocharger with charge air cooler
Lubrication	pressure system with full-flow spin-on filter and oil-to-water cooler
Air Cleaner	dual safety element dry type, evacuator valve
Slope Operation (maximum angle)	45 deg.

## Cooling

Blower-type cooling fan	
Engine Coolant Rating	-34 deg. F (-37 deg. C)
Engine Radiator	10 fins per in.
Hydrostatic Cooler and Hydraulic Cooler (oil/air)	10 fins per in.
Charge Air Cooler (air/air)	10 fins per in.

## Powertrain

<b>Transmission</b>	dual-path, electronic-controlled, hydrostatic drive; load-sensing, automatically adjusts speed and power to match changing load conditions; each track is powered by a variable-displacement piston pump and two-speed motor combination; decelerator controls speed; transmission neutral lock with safety start switch
Travel Speeds (forward and reverse)	0-5.0 mph (0-8.0 km/h)
<b>Steering</b>	single-lever steering, direction control, and counterrotation; full power turns and infinitely variable track speeds provide unlimited maneuverability and optimum control; hydrostatic steering eliminates steering clutches and brakes
<b>Final Drives</b>	heavy-duty triple-reduction final drives attach directly to the mainframe; isolated from track and dozer frame loads
<b>Brakes</b>	hydrostatic (dynamic) braking stops the machine whenever the direction-control lever is moved to neutral or whenever the decelerator is depressed to the detent
<b>Service Brakes</b>	hydrostatic braking when direction-control lever is moved to neutral or when the decelerator is depressed to the detent
<b>Parking Brakes</b>	wet, multi-disc applied automatically when engine stops, when decelerator pedal depressed to brake position, when unit is in neutral for three seconds with detected motion, or when the park lock lever is in park position; machine cannot be driven with brake applied

## Hydraulics

Open-center hydraulic system with gear pump	
Pump Flow @ 2,200 rpm	15 gpm (56.8 L/min.)
System Relief Pressure	3,000 psi (20 684 kPa)
Controls	3-function hydraulic valve with low-effort single-lever T-bar

## Electrical

Voltage	12 volt
Battery Capacity	950 CCA
Reserve Capacity	190 min.
Alternator Rating	65 amp
<b>Standard Lights</b>	3 total: grille mounted (2) and rear mounted (1), and rear reflectors (2)

Undercarriage	550J LT	550J LGP
Tracks	John Deere Dura-Trax™, deep-heat-treated, pins and bushings sealed for life; rollers and idlers permanently sealed and lubricated	John Deere Dura-Trax, deep-heat-treated, pins and bushings sealed for life; rollers and idlers permanently sealed and lubricated
Track Gauge (standard)	5 ft. 1 in. (1549 mm)	5 ft. 9 in. (1753 mm)
Grouser Width (closed center, single bar)	18 in. (457 mm)	24 in. (610 mm)
Chain	sealed and lubricated	sealed and lubricated
Shoes (each side)	40	40
Track Rollers (single flange, each side)	6	6
<b>Undercarriage Track</b>	<i>Standard</i>	<i>Standard</i>
Track Length on Ground	7 ft. 2 in. (2184 mm)	7 ft. 2 in. (2184 mm)
Ground Contact Area	3,096 sq. in. (19 974 cm <sup>2</sup> )	4,128 sq. in. (26 632 cm <sup>2</sup> )
Ground Pressure	5.5 psi (37.9 kPa)	4.2 psi (29.0 kPa)
Track Pitch	6.29 in. (160 mm)	6.29 in. (160 mm)
	<i>Maximum Life</i>	<i>Maximum Life</i>
	7 ft. 1 in. (2154 mm)	7 ft. 1 in. (2154 mm)
	3,050 sq. in. (19 677 cm <sup>2</sup> )	4,070 sq. in. (26 258 cm <sup>2</sup> )
	5.7 psi (39.1 kPa)	4.6 psi (31.4 kPa)
	6.73 in. (171 mm)	6.73 in. (171 mm)

### Serviceability 550J LT / 550J LGP

#### Refill Capacities

Fuel Tank	47 gal. (178 L)
Cooling System with Recovery Tank	17 qt. (16 L)
Engine Oil with Filter	15 qt. (14 L)
Transmission Reservoir with Filter	11.3 gal. (43 L)
Final Drive (each)	7 qt. (6.6 L)
Hydraulic Reservoir and Filter	8.5 gal. (32.2 L)

### Operating Weights 550J LT 550J LGP

With Full Fuel Tank, 175-lb. (79 kg) Operator, ROPS, and Standard Equipment	
105-in. (2667 mm) Blade and 18-in. (457 mm) Track Shoes	17,016 lb. (7718 kg)
124-in. (3150 mm) Blade and 24-in. (610 mm) Track Shoes	18,252 lb. (8279 kg)

#### Optional Components

Maximum Life Undercarriage	290 lb. (132 kg)	290 lb. (132 kg)
Rock Guards (4)	288 lb. (131 kg)	288 lb. (131 kg)
For Maximum Life Undercarriage	193 lb. (88 kg)	193 lb. (88 kg)
Cab	675 lb. (306 kg)	675 lb. (306 kg)
Counterweight		
Rear (each)	330 lb. (150 kg)	330 lb. (150 kg)
Front (each)	240 lb. (109 kg)	240 lb. (109 kg)
Front Tow Hook	33 lb. (15 kg)	33 lb. (15 kg)
Retrieval Hitch	50 lb. (23 kg)	50 lb. (23 kg)
Extended Drawbar	72 lb. (33 kg)	72 lb. (33 kg)
Limb Risers	229 lb. (104 kg)	229 lb. (104 kg)
Screens		
Rear	76 lb. (34 kg)	76 lb. (34 kg)
Side	94 lb. (43 kg)	94 lb. (43 kg)
Front and Doors	179 lb. (81 kg)	179 lb. (81 kg)
Winch		
4000S	1,437 lb. (652 kg)	1,437 lb. (652 kg)
Fairlead, 4-Roller	187 lb. (85 kg)	187 lb. (85 kg)
Ripper, Parallelogram	2,163 lb. (981 kg)	2,163 lb. (981 kg)
97-in. (2464 mm) Blade, All-Hydraulic Heavy-Duty C Frame	- 151 lb. (- 68 kg)	
115-in. (2921 mm) Blade, All-Hydraulic Heavy-Duty C Frame (adjust to base weight)	- 38 lb. (- 17 kg)	
121-in. (3073 mm) Blade, All-Hydraulic Heavy-Duty C Frame (adjust to base weight)	22 lb. (10 kg)	
All-Hydraulic Heavy-Duty C Frame (less blade; adjust to base weight)	- 1,212 lb. (- 550 kg)	- 1,373 lb. (- 623 kg)

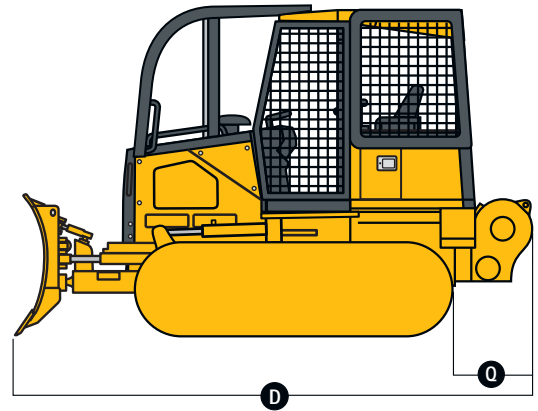
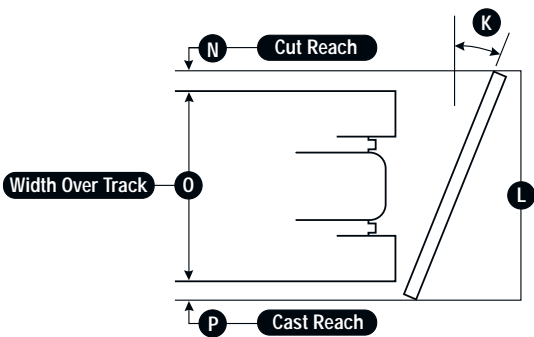
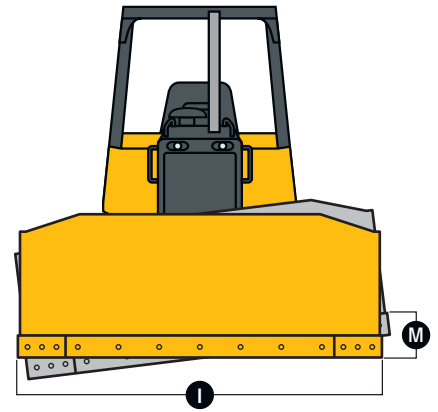
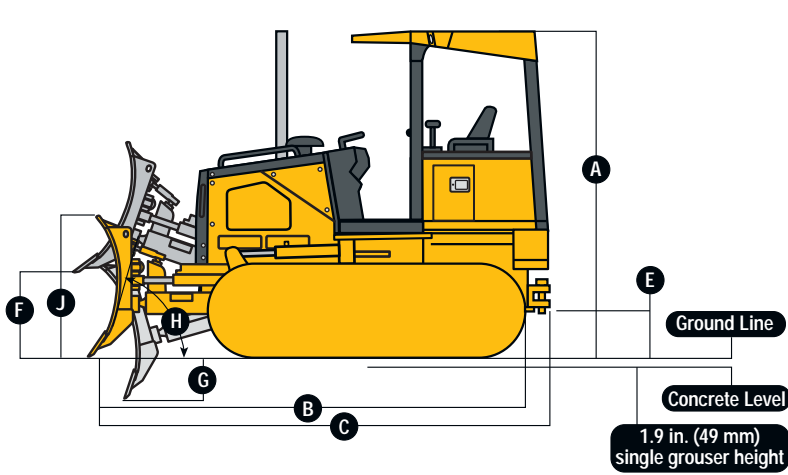

**Machine Dimensions**

**550J LT**

**550J LGP**

<b>A</b> Overall Height (ROPS or cab) . . . . .	9 ft. 0 in. (2743 mm)	9 ft. 0 in. (2743 mm)
Height of Grousers . . . . .	1.9 in. (48 mm)	1.9 in. (48 mm)
<b>B</b> Overall Length . . . . .	13 ft. 3 in. (4039 mm)	13 ft. 3 in. (4039 mm)
<b>C</b> Overall Length with Extended Drawbar . . . . .	13 ft. 5 in. (4089 mm)	13 ft. 5 in. (4089 mm)
<b>D</b> Overall Length with Winch . . . . .	14 ft. 11 in. (4547 mm)	14 ft. 11 in. (4547 mm)
<b>E</b> Ground Clearance with Single-Bar Grouser (excluding grouser height) . . . . .	14 in. (345 mm)	14 in. (345 mm)
<b>F</b> Blade Lift Height . . . . .	31 in. (798 mm)	31 in. (798 mm)
<b>G</b> Blade Digging Depth . . . . .	21 in. (523 mm)	20.6 in. (523 mm)
<b>H</b> Blade Cutting Edge Angle (adjustable) . . . . .	52 to 60 deg.	52 to 60 deg.

**Blade Specs**

<b>I</b> Width . . . . .	105 in. (2667 mm)	115 in. (2921 mm)	115 in. (2921 mm)	124 in. (3150 mm)
<b>J</b> Height . . . . .	3 ft. 2 in. (955 mm)	3 ft. 2 in. (955 mm)	3 ft. 2 in. (955 mm)	2 ft. 11 in. (894 mm)
SAE Capacity . . . . .	2.35 cu. yd. (1.80 m <sup>3</sup> )	2.57 cu. yd. (1.96 m <sup>3</sup> )	2.57 cu. yd. (1.96 m <sup>3</sup> )	2.46 cu. yd. (1.88 m <sup>3</sup> )
<b>K</b> Blade Angle . . . . .	22.2 deg.	22.2 deg.	22.2 deg.	22.2 deg.
<b>L</b> Angled Width . . . . .	8 ft. 1 in. (2469 mm)	8 ft. 11 in. (2705 mm)	8 ft. 11 in. (2705 mm)	9 ft. 7 in. (2916 mm)
<b>M</b> Tilt . . . . .	14.3 in. (363 mm)	15.7 in. (399 mm)	15.7 in. (399 mm)	16.9 in. (429 mm)
<b>N</b> Cut Reach . . . . .	4.6 in. (116.84 mm)	9.2 in. (233.68 mm)	2.2 in. (56 mm)	6.4 in. (163 mm)
<b>O</b> Width Over Track . . . . .	6 ft. 7 in. (2007 mm)	6 ft. 7 in. (2007 mm)	7 ft. 9 in. (2362 mm)	7 ft. 9 in. (2362 mm)
<b>P</b> Cast Reach . . . . .	13.6 in. (345 mm)	18.3 in. (465 mm)	11 in. (287 mm)	15.4 in. (391 mm)

**Rear Ripper**

**550J LT / 550J LGP**

<b>Q</b>	400S Winch Length . . . . .	30 in. (752 mm)
<b>R</b>	Maximum Penetration . . . . .	20 in. (508 mm)
<b>S</b>	Maximum Clearance Under Tip . . . . .	20 in. (508 mm)
<b>T</b>	Overall Length (lowered position) . . . . .	57 in. (1450 mm)
<b>T'</b>	Overall Length (raised position) . . . . .	40 in. (1015 mm)
<b>U</b>	Overall Beam Width . . . . .	72 in. (1830 mm)
<b>V</b>	Slope Angle (full raise) . . . . .	40 deg.
<b>W</b>	Ripping Width . . . . .	66 in. (1670 mm)
<b>X</b>	Distance Between Shanks (3 installed) . . . . .	32 in. (806 mm)
	Distance Between Holes In Shank . . . . .	3.1 in. (80 mm)

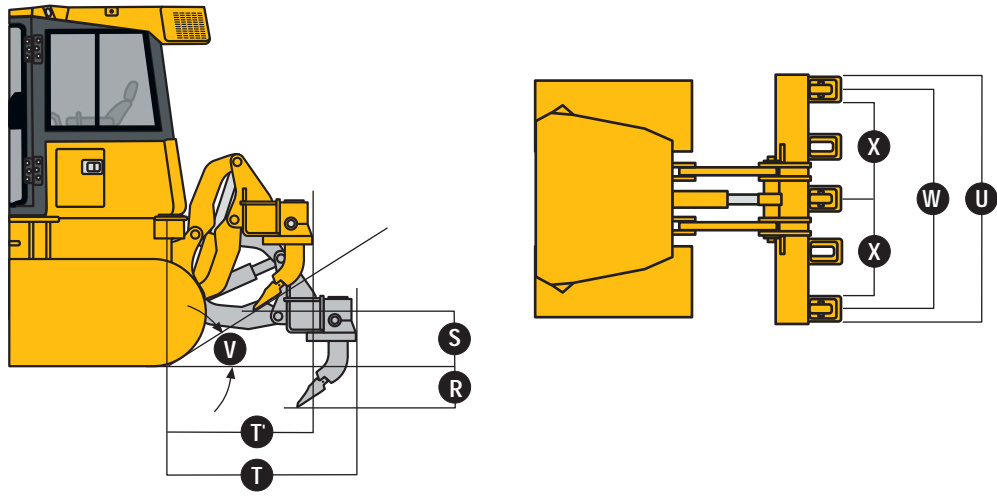

**Drawbar Pull**

Crawler Speed vs Ground Pull . . . . . usable pull will depend on traction and weight of tractor

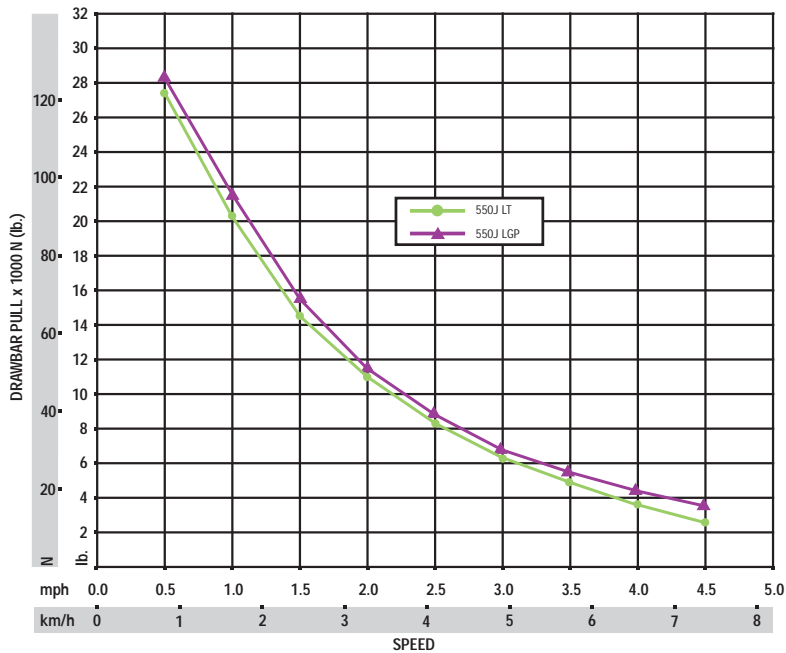

# Specifications

## Engine 650J LT / 650J XLT / 650J LGP

Manufacturer and Model	John Deere 4045H
Non-Road Emission Standards	certified to EPA Tier 3 emissions
Cylinders	4
Displacement	276 cu. in. (4.5 L)
SAE Net Rated Power @ 2,200 rpm	99 hp (74 kW)
Net Peak Torque @ 1,200 rpm	329 lb.-ft. (447 Nm)
Aspiration	altitude-compensating turbocharger with charge air cooler
Lubrication	pressure system with full-flow spin-on filter and oil-to-water cooler
Air Cleaner	dual safety element dry type, evacuator valve
Slope Operation (maximum angle)	45 deg.

## Cooling

Blower-type cooling fan	
Engine Coolant Rating	-34 deg. F (-37 deg. C)
Engine Radiator	10 fins per in.
Hydrostatic Cooler and Hydraulic Cooler (oil/air)	10 fins per in.
Charge Air Cooler (air/air)	10 fins per in.

## Powertrain

<b>Transmission</b>	dual-path, electronic-controlled, hydrostatic drive; load-sensing, automatically adjusts speed and power to match changing load conditions; each track is powered by a variable-displacement piston pump and two-speed motor combination; decelerator controls speed; transmission neutral lock with safety start switch
Travel Speeds (forward and reverse)	0-5.0 mph (0-8.0 km/h)
<b>Steering</b>	single-lever steering, direction control, and counterrotation; full power turns and infinitely variable track speeds provide unlimited maneuverability and optimum control; hydrostatic steering eliminates steering clutches and brakes
<b>Final Drives</b>	heavy-duty triple-reduction final drives attach directly to the mainframe; isolated from track and dozer frame loads
<b>Brakes</b>	hydrostatic (dynamic) braking stops the machine whenever the direction-control lever is moved to neutral or whenever the decelerator is depressed to the detent
<b>Service Brakes</b>	hydrostatic braking when direction-control lever is moved to neutral or when the decelerator is depressed to the detent
<b>Parking Brakes</b>	exclusive safety feature engaged wet, multiple-disc brakes automatically whenever the engine stops, whenever the operator depresses the decelerator pedal to the brake position, whenever the unit is in neutral for three seconds (with detected motion), or whenever the park lock lever is in the park position; machine cannot be driven with brake applied, reducing wear-out or need for adjustment

## Hydraulics

Open-center hydraulic system with gear pump	
Pump Flow @ 2,200 rpm	15 gpm (56.8 L/min.)
System Relief Pressure	3,000 psi (20 684 kPa)
Filter, Return Oil	10 micron
Controls	3-function hydraulic valve with low-effort single-lever T-bar

## Electrical

Voltage	12 volt
Battery Capacity	950 CCA
Reserve Capacity	190 min.
Alternator Rating	65 amp
<b>Standard Lights</b>	3 total: grille mounted (2) and rear mounted (1), and rear reflectors (2)

## Undercarriage

	650J LT	650J XLT	650J LGP
<b>Tracks</b>	John Deere Dura-Trax, deep-heat-treated, pins and bushings sealed for life; rollers and idlers permanently sealed and lubricated	John Deere Dura-Trax, deep-heat-treated, pins and bushings sealed for life; rollers and idlers permanently sealed and lubricated	John Deere Dura-Trax, deep-heat-treated, pins and bushings sealed for life; rollers and idlers permanently sealed and lubricated

<b>Undercarriage (continued)</b>	<b>650J LT</b>		<b>650J XLT</b>		<b>650J LGP</b>	
Track Gauge (standard)	5 ft. 1 in. (1549 mm)		5 ft. 1 in. (1549 mm)		5 ft. 9 in. (1753 mm)	
Grouser Width (closed center, single bar)	18 in. (457 mm)		18 in. (457 mm)		28 in. (711 mm)	
Chain	sealed and lubricated		sealed and lubricated		sealed and lubricated	
Shoes (each side)	38		40		40	
Track Rollers (single flange, each side)	6		7		7	
<b>Undercarriage Track</b>	<i>Standard</i>	<i>Maximum Life</i>	<i>Standard</i>	<i>Maximum Life</i>	<i>Standard</i>	<i>Maximum Life</i>
Track Length on Ground	7 ft. 3 in. (2210 mm)	7 ft. 3 in. (2210 mm)	7 ft. 8 in. (2337 mm)	7 ft. 8 in. (2337 mm)	7 ft. 8 in. (2337 mm)	7 ft. 8 in. (2337 mm)
Ground Contact Area	3,132 sq. in. (20 206 cm <sup>2</sup> )	3,132 sq. in. (20 206 cm <sup>2</sup> )	3,312 sq. in. (21 368 cm <sup>2</sup> )	3,312 sq. in. (21 368 cm <sup>2</sup> )	5,152 sq. in. (33 239 cm <sup>2</sup> )	5,152 sq. in. (33 239 cm <sup>2</sup> )
Ground Pressure	5.9 psi (40.7 kPa)	6.1 psi (42.1 kPa)	5.6 psi (38.6 kPa)	5.8 psi (40.0 kPa)	3.8 psi (26.2 kPa)	4.0 psi (27.6 kPa)
Track Pitch	6.73 in. (171 mm)	6.73 in. (171 mm)	6.73 in. (171 mm)	6.73 in. (171 mm)	6.73 in. (171 mm)	6.73 in. (171 mm)

## Serviceability

### Refill Capacities

Fuel Tank	47 gal. (178 L)
Cooling System with Recovery Tank	17 qt. (16 L)
Engine Oil with Filter	15 qt. (14 L)
Transmission Reservoir with Filter	11.3 gal. (43 L)
Final Drive (each)	7 qt. (6.6 L)
Hydraulic Reservoir and Filter	8.5 gal. (32.2 L)

## Operating Weights

With Full Fuel Tank, 175-lb. (79 kg) Operator, ROPS, and Standard Equipment

105-in. (2667 mm) Blade and 18-in. (457 mm) Track Shoes	18,560 lb. (8419 kg)	18,600 lb. (8455 kg)	N/A
128-in. (3251 mm) Blade and 28-in. (711 mm) Track Shoes			19,750 lb. (8977 kg)

### Optional Components

Maximum Life Undercarriage	610 lb. (277 kg)	650 lb. (295 kg)	735 lb. (333 kg)
Rock Guards (4)	260 lb. (118 kg)	295 lb. (134 kg)	260 lb. (118 kg)
Rock Guards			
For Maximum Life Undercarriage	181 lb. (82 kg)	211 lb. (96 kg)	211 lb. (96 kg)
20-in. (508 mm) Track Shoes	174 lb. (79 kg)	183 lb. (83 kg)	- 760 lb. (- 344 kg)
24-in. (610 mm) Track Shoes (adjust to base weight)			- 380 lb. (- 172 kg)
Cab	675 lb. (306 kg)	675 lb. (306 kg)	675 lb. (306 kg)
Counterweight			
Rear (each)	330 lb. (150 kg) in base	330 lb. (150 kg)	330 lb. (150 kg)
Front (each)	240 lb. (209 kg) in base	240 lb. (209 kg)	240 lb. (209 kg)
Front Tow Hook	in base	in base	in base
Retrieval Hitch	50 lb. (23 kg)	50 lb. (23 kg)	50 lb. (23 kg)
Extended Drawbar	72 lb. (33 kg)	72 lb. (33 kg)	72 lb. (33 kg)
Limb Risers	229 lb. (104 kg)	229 lb. (104 kg)	229 lb. (104 kg)
Screens			
Rear	76 lb. (34 kg)	76 lb. (34 kg)	76 lb. (34 kg)
Side	94 lb. (43 kg)	94 lb. (43 kg)	94 lb. (43 kg)
Front and Doors	179 lb. (81 kg)	179 lb. (81 kg)	179 lb. (81 kg)
Winch			
4000S	1,437 lb. (652 kg)	1,437 lb. (652 kg)	1,437 lb. (652 kg)
Fairlead, 4-Roller	187 lb. (85 kg)	187 lb. (85 kg)	187 lb. (85 kg)
Ripper, Parallelogram	2,163 lb. (981 kg)	2,163 lb. (981 kg)	2,163 lb. (981 kg)
All-Hydraulic Heavy-Duty C Frame (less blade)	- 1,384 lb. (- 628 kg)	- 1,384 lb. (- 628 kg)	- 1,470 lb. (- 667 kg)
115-in. (2921 mm) Blade, All-Hydraulic Heavy-Duty C Frame (adjust to base weight)			- 134 lb. (- 61 kg)
121-in. (3073 mm) Blade, All-Hydraulic Heavy-Duty C Frame (adjust to base weight)			- 74 lb. (- 33 kg)

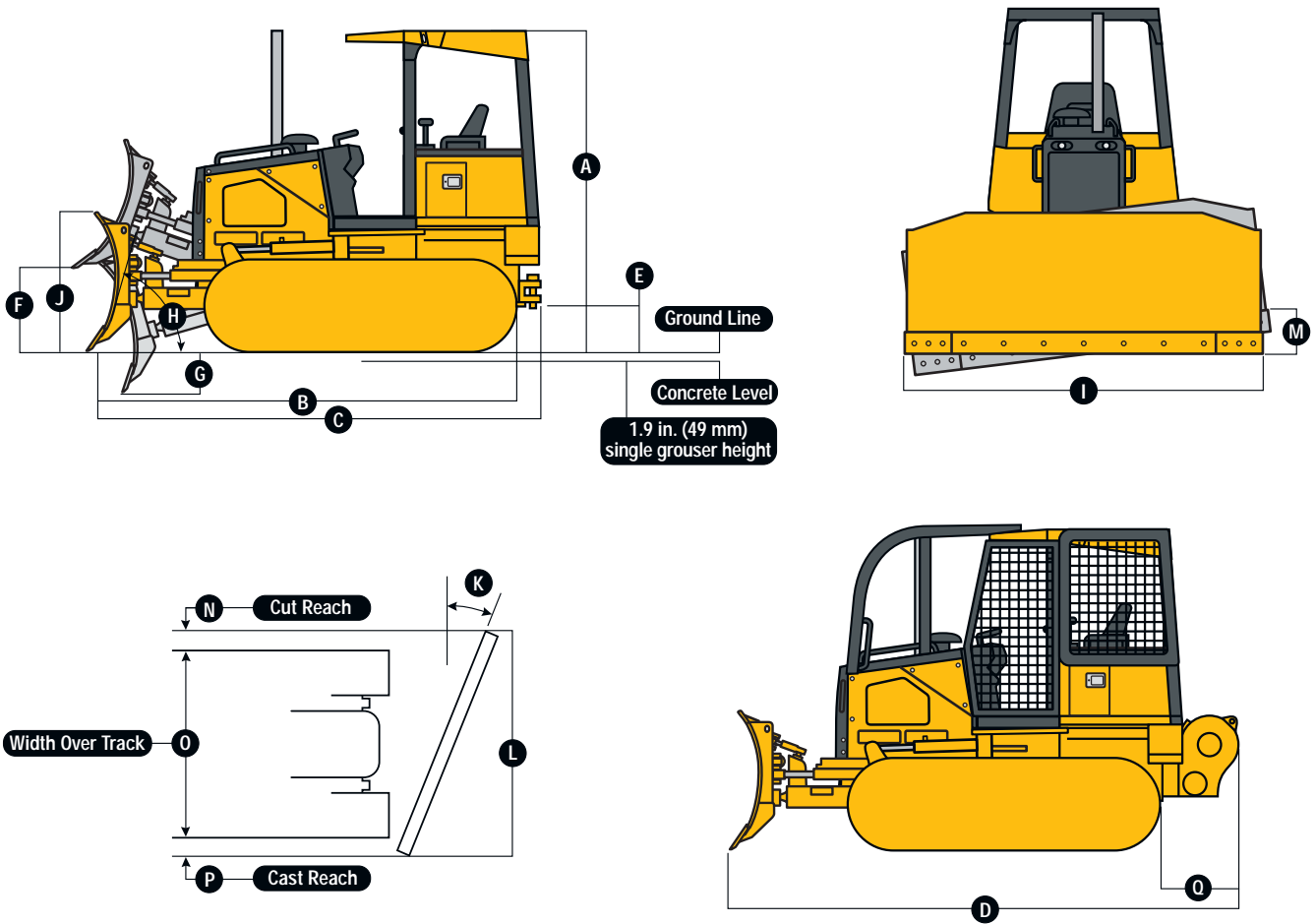

**Machine Dimensions**

	<b>650J LT</b>	<b>650J XLT</b>	<b>650J LGP</b>
<b>A</b> Overall Height (ROPS or cab) . . . . .	9 ft. 1 in. (2769 mm)	9 ft. 1 in. (2769 mm)	9 ft. 1 in. (2769 mm)
Height of Grousers . . . . .	1.9 in. (48 mm)	1.9 in. (48 mm)	1.9 in. (48.3 mm)
<b>B</b> Overall Length . . . . .	13 ft. 5 in. (4089 mm)	13 ft. 11 in. (4242 mm)	13 ft. 11 in. (4242 mm)
<b>C</b> Overall Length with Extended Drawbar . . . . .	13 ft. 10 in. (4216 mm)	14 ft. 1 in. (4293 mm)	14 ft. 1 in. (4293 mm)
<b>D</b> Overall Length with Winch . . . . .	14 ft. 11 in. (4547 mm)	15 ft. 6 in. (4724 mm)	15 ft. 6 in. (4724 mm)
<b>E</b> Ground Clearance with Single-Bar Grouser (excluding grouser height) . . . . .	14 in. (363 mm)	14.3 in. (363 mm)	14.3 in. (363 mm)
<b>Maximum Life Undercarriage</b> . . . . .	14.5 in. (368 mm)	14.5 in. (368 mm)	14.5 in. (368 mm)
<b>F</b> Blade Lift Height . . . . .	32 in. (818 mm)	32.2 in. (818 mm)	32.2 in. (818 mm)
<b>G</b> Blade Digging Depth . . . . .	20 in. (500 mm)	19.7 in. (500 mm)	19.7 in. (500 mm)
<b>H</b> Blade Cutting Edge Angle (adjustable) . . . . .	52 to 60 deg.	52 to 60 deg.	52 to 60 deg.

**650J LT Blade Specs**

	<b>650J LT</b>	<b>650J XLT</b>	<b>650J LGP</b>
<b>I</b> Width . . . . .	105 in. (2667 mm)	115 in. (2921 mm)	124 in. (3150 mm)
<b>J</b> Height . . . . .	3 ft. 6 in. (1067 mm)	3 ft. 2 in. (955 mm)	2 ft. 11 in. (894 mm)
SAE Capacity . . . . .	2.91 cu. yd. (2.22 m <sup>3</sup> )	2.57 cu. yd. (1.96 m <sup>3</sup> )	2.46 cu. yd. (1.88 m <sup>3</sup> )
<b>K</b> Blade Angle . . . . .	22.2 deg.	22.2 deg.	22.2 deg.
<b>L</b> Angled Width . . . . .	8 ft. 1 in. (2469 mm)	8 ft. 11 in. (2705 mm)	9 ft. 7 in. (2916 mm)
<b>M</b> Tilt . . . . .	14.3 in. (363 mm)	15.7 in. (399 mm)	16.9 in. (429 mm)
<b>N</b> Cut Reach . . . . .	4.6 in. (117 mm)	9.2 in. (233.68 mm)	13.4 in. (340.36 mm)
<b>O</b> Width Over Track . . . . .	6 ft. 7 in. (2007 mm)	6 ft. 7 in. (2007 mm)	6 ft. 7 in. (2007 mm)
<b>P</b> Cast Reach . . . . .	13.6 in. (345 mm)	18.3 in. (465 mm)	22.4 in. (569 mm)

### 650J XLT Blade Specs

<b>I</b> Width	105 in. (2667 mm)	115 in. (2921 mm)	124 in. (3150 mm)
<b>J</b> Height	3 ft. 6 in. (1067 mm)	3 ft. 2 in. (955 mm)	2 ft. 11 in. (894 mm)
SAE Capacity	2.9 cu. yd. (2.22 m <sup>3</sup> )	2.57 cu. yd. (1.96 m <sup>3</sup> )	2.46 cu. yd. (2.0 m <sup>3</sup> )
<b>K</b> Blade Angle	22.2 deg.	22.2 deg.	22.2 deg.
<b>L</b> Angled Width	8 ft. 1 in. (2469 mm)	8 ft. 11 in. (2705 mm)	9 ft. 7 in. (2916 mm)
<b>M</b> Tilt	14.3 in. (363 mm)	15.7 in. (399 mm)	16.9 in. (429 mm)
<b>N</b> Cut Reach	4.6 in. (117 mm)	9.2 in. (233.68 mm)	13.4 in. (340 mm)
<b>O</b> Width Over Track	6 ft. 7 in. (2007 mm)	6 ft. 7 in. (2007 mm)	6 ft. 7 in. (2007 mm)
<b>P</b> Cast Reach	13.6 in. (345 mm)	18.3 in. (465 mm)	22.4 in. (569 mm)

### 650J LGP Blade Specs

<b>I</b> Width	115 in. (2921 mm)	124 in. (3150 mm)	128 in. (3251 mm)
<b>J</b> Height	3 ft. 2 in. (955 mm)	2 ft. 11 in. (894 mm)	3 ft. 2 in. (955 mm)
SAE Capacity	2.57 cu. yd. (1.96 m <sup>3</sup> )	2.46 cu. yd. (1.88 m <sup>3</sup> )	2.91 cu. yd. (2.22 m <sup>3</sup> )
<b>K</b> Blade Angle	22.2 deg.	22.2 deg.	22.2 deg.
<b>L</b> Angled Width	8 ft. 11 in. (2705 mm)	9 ft. 7 in. (2916 mm)	9 ft. 11 in. (3010 mm)
<b>M</b> Tilt	15.7 in. (399 mm)	16.9 in. (429 mm)	17.5 in. (445 mm)
<b>N</b> Cut Reach	0.2 in. (5 mm)	4.4 in. (112 mm)	6.2 in. (157 mm)
<b>O</b> Width Over Track	8 ft. 1 in. (2464 mm)	8 ft. 1 in. (2464 mm)	8 ft. 1 in. (2464 mm)
<b>P</b> Cast Reach	9.3 in. (236 mm)	13.4 in. (340 mm)	15.3 in. (389 mm)

### Rear Ripper

#### 650J LT / 650J XLT / 650J LGP

<b>Q</b> 4000S Winch Length	30 in. (752 mm)
<b>R</b> Maximum Penetration	20 in. (508 mm)
<b>S</b> Maximum Clearance Under Tip	20 in. (508 mm)
<b>T</b> Overall Length (lowered position)	57 in. (1450 mm)
<b>T'</b> Overall Length (raised position)	40 in. (1015 mm)
<b>U</b> Overall Beam Width	72 in. (1830 mm)
<b>V</b> Slope Angle (full raise)	40 deg.
<b>W</b> Ripping Width	66 in. (1670 mm)
<b>X</b> Distance Between Shanks (3 installed)	32 in. (806 mm)
Distance Between Holes In Shank	3.1 in. (80 mm)

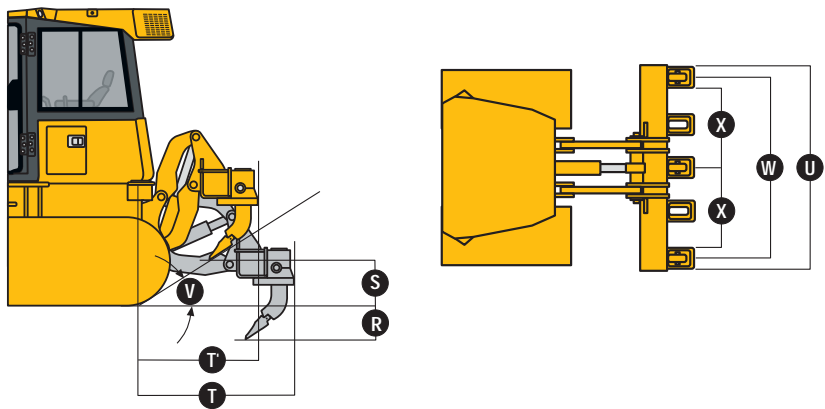

### Drawbar Pull

Crawler Speed vs Ground Pull ..... usable pull will depend on traction and weight of tractor

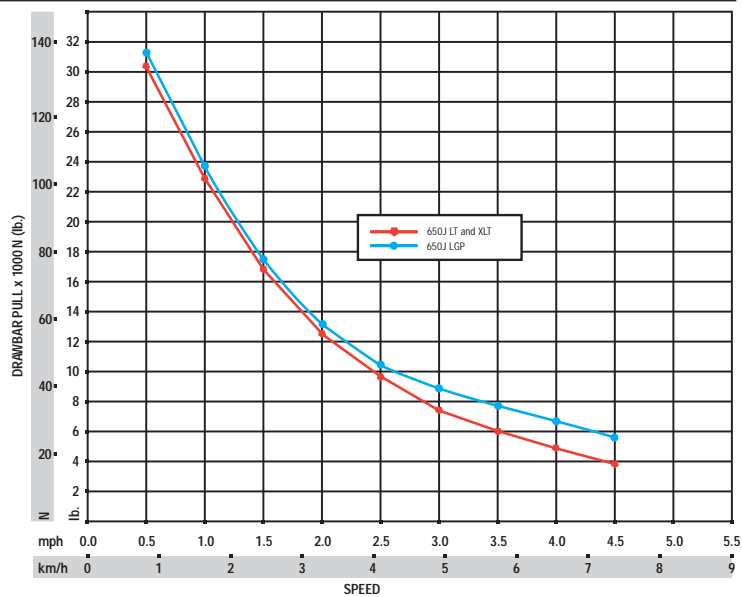

## 450J / 550J / 650J CRAWLER DOZERS

Key: ● Standard equipment ▲ Optional or special equipment

See your John Deere dealer for further information.

### 450 550 650 Engine

- ● ● Certified to EPA Tier 3 emissions
- ● ● Electronic control with automatic engine protection
- ● ● Dual safety element dry-type air cleaner, evacuator valve
- ● ● Muffler, self draining, under hood, with vertical stack
- ▲ ▲ ▲ Environmental service drains
- ▲ ▲ ▲ Ether start aid
- ▲ ▲ ▲ Engine coolant heater, 110 volts
- ▲ ▲ ▲ Engine coolant heater, fuel fired
- ▲ ▲ ▲ Chrome exhaust
- ▲ ▲ ▲ Fuel filter heater
- ▲ ▲ ▲ Rotary ejection engine air precleaner

### Cooling

- ● ● Enclosed safety fan guard (conforms to SAE J1308 and ISO3457)
- ● ● Perforated engine side shields
- ● ● Heavy-duty grille
- ▲ ▲ ▲ Extreme-duty grille
- ▲ ▲ ▲ Radiator sand screens

### Transmission

- ● ● Remote diagnostic test ports
- ▲ ▲ ▲ Environmental service drains

### Hydraulic System

- ● ● Three-function hydraulics
- ▲ ▲ ▲ Four-function hydraulics with rear plumbing
- ▲ ▲ ▲ Drive-through hydraulic pump for use with winch
- ▲ Integrated Grade Control (IGC)

### Mainframe, Access Panels

- ● ● Front tow loop (bolt-on)
- ● ● Reinforced engine and mid-frame bottom guards
- ● ● Integral transmission guard
- ● ● Vandal protection: Engine access door / Side tank access doors / Fuel tank / Instrument panel / Transmission reservoir / Hydraulic reservoir

### Attachments

- ▲ ▲ ▲ Retrieval hitch with pin
- ▲ ▲ ▲ Extended rigid drawbar with pin for pull-type implements
- ▲ ▲ ▲ Drawbar, extended for winch (with or without Fairlead)
- ▲ ▲ ▲ Ripper, parallelogram with five shank pockets and three teeth
- ▲ ▲ ▲ Winch, John Deere, power in/free spool out OR power out
- ▲ ▲ ▲ Four-roller fairlead for winch

### 450 550 650 Attachments (continued)

- ▲ ▲ ▲ Root-rake blade attachment
- ▲ ▲ ▲ Rear-mounted toolbox

### Undercarriage

- ● ● Full-length, smooth-surface track frame covers
- ● ● Chain guides, front and rear
- ● ● Single-flange roller
- ▲ ▲ ● Double-flange rollers
- ▲ ▲ ▲ Extended life undercarriage with SC-2™ bushings
- ▲ ▲ ▲ Full-length rock guards
- ▲ ▲ ▲ Center track chain guide
- ▲ ▲ ▲ Maximum Life Undercarriage System

### Canopy Cab Operator's Station / Electrical

- ● Retractable seat belts, 2 in. (51 mm) (conform to SAE J386)
- ▲ ▲ Retractable seat belts, 3 in. (76 mm) (conform to SAE J386)
- ▲ ▲ Accessories: Convex wide-angle interior rearview mirror / Thigh cushions (2) / Seat-side lockable storage box/lunch box/cup holder
- ● Power port, 12 volts
- ▲ ▲ Lockable side-seat storage compartment
- ● Air conditioner, 24,000 Btu
- ● Tinted glass
- ● Dome light
- ● Heater (roof mount)
- ● Front and door wipers
- ● Mechanical suspension vinyl seat
- ● Mechanical suspension fabric seat
- ▲ ▲ Air suspension vinyl seat
- ▲ ▲ Air suspension fabric seat
- ▲ ▲ Under-seat heater
- ▲ ▲ Rear wiper
- ▲ ▲ AM/FM, weather-band radio, clock
- ▲ ▲ External-mounted attachment mirror
- ● Sealed alternator, 65 amps
- ● Master electrical disconnect switch
- ● Lights, grille mounted (2), rear mounted (1)
- ▲ ▲ Work lights, roof mounted
- ● Battery, single, 12 volts
- ▲ ▲ Battery, dual, 12 volts
- ▲ ▲ JDLink™ wireless communication system

## CONTROL OWNING AND OPERATING COSTS

Customer Personal Service (CPS) is part of John Deere's proactive, fix-before-fail strategy on machine maintenance that will help control costs, increase profits, and reduce stress. Included in this comprehensive lineup of ongoing programs and services are:

**Fluid analysis program** – tells you what's going on inside *all* of your machine's major components so you'll know if there's a problem *before* you see a decline in performance. Fluid analysis is included in most extended coverage and preventive-maintenance agreements.

**Component life-cycle data** – gives you vital information on the projected life span of components and lets you make informed decisions on machine maintenance by telling you approximately how many hours of use you can expect from an engine, transmission, or hydraulic pump. This information can be used to preempt catastrophic downtime by servicing major components at about 80 percent of their life cycle.

**Preventive Maintenance (PM) agreements** – give you a fixed cost for maintaining a machine for a given period of time. They also help you avoid downtime by

ensuring that critical maintenance work gets done right and on schedule. On-site preventive maintenance service performed where and when you need it helps protect you from the expense of catastrophic failures and lets you avoid waste-disposal hassles.

**Extended coverage** – gives you a fixed cost for machine repairs for a given period of time so you can effectively manage costs. Whether you work in a severe-service setting or just want to spread the risk of doing business, this is a great way to custom-fit coverage for your operation. And an extended coverage contract also travels well because it's backed by John Deere and is honored by *all* Deere construction dealers.

**Customer Support Advisors (CSAs)** – Deere believes the CSA program lends a *personal* quality to Customer Personal Service (CPS). Certified CSAs have the knowledge and skills for helping make important decisions on machine maintenance and repair. Their mission is to help you implement a plan that's right for *your* business and take the burden of machine maintenance off your shoulders.



JOHN DEERE

DKAJUDZR Litho in U.S.A. (08-05)

Net engine power is with standard equipment including air cleaner, exhaust system, alternator, and cooling fan at test conditions specified per ISO9249.

Specifications and design subject to change without notice. Wherever applicable, specifications are in accordance with SAE standards. Except where otherwise noted, these specifications are based on units with standard equipment, rollover protective structures, full fuel tanks, and 175-lb. (79 kg) operators.

